

EAC

инструкция по сборке

**Шкаф двухдверный арт.
5756, 5893**

Дверь шкафа с зеркалом 5895

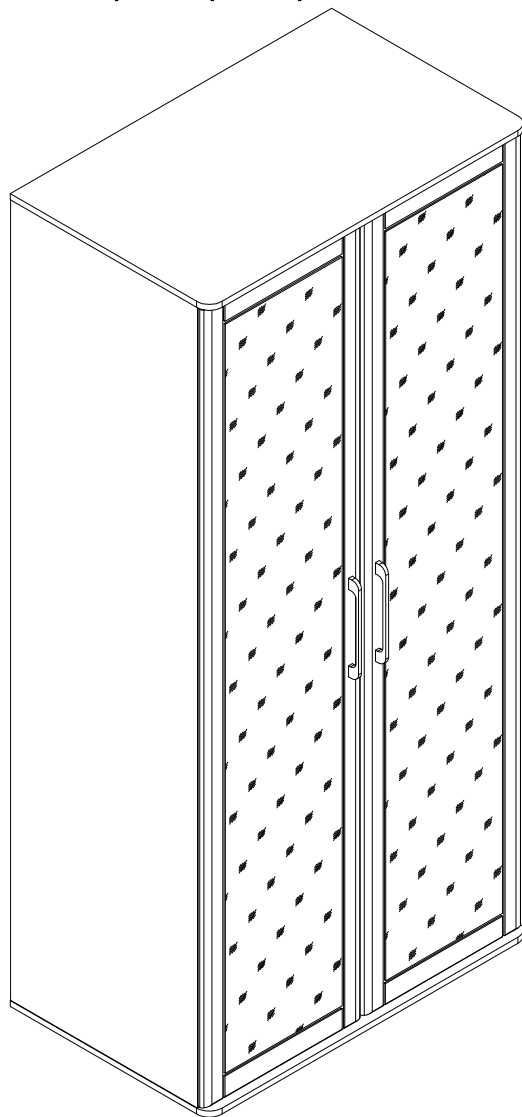

Дверь шкафа без зеркала 5894

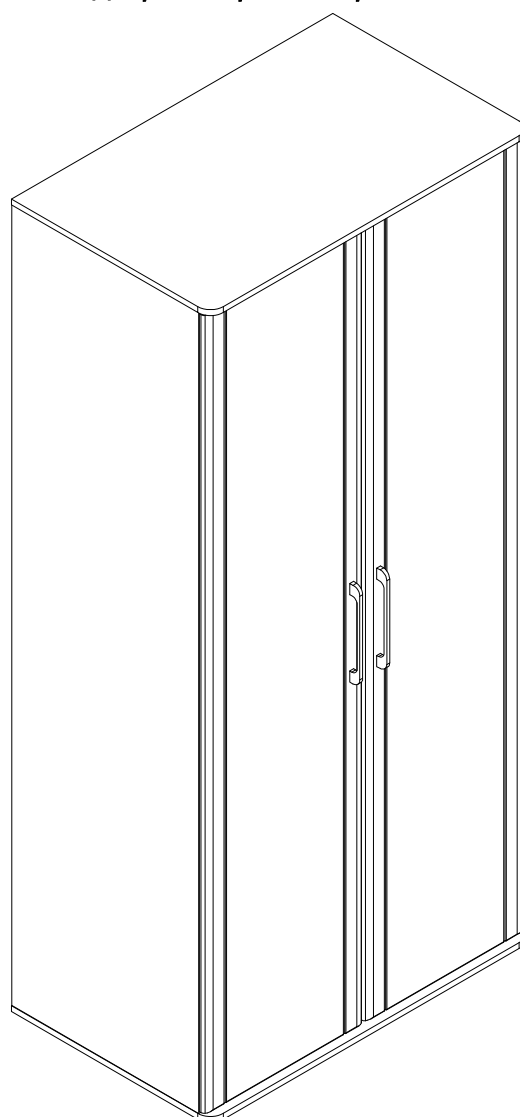

габаритные размеры

высота - 2204 мм

ширина - 1002 мм

глубина - 621 мм

единая справочная служба:

8 800 100-50-22

(звонок по России бесплатный)

LAZURIT
FURNITURE FACTORY

Каркас шкафа 5893

Вариант 1

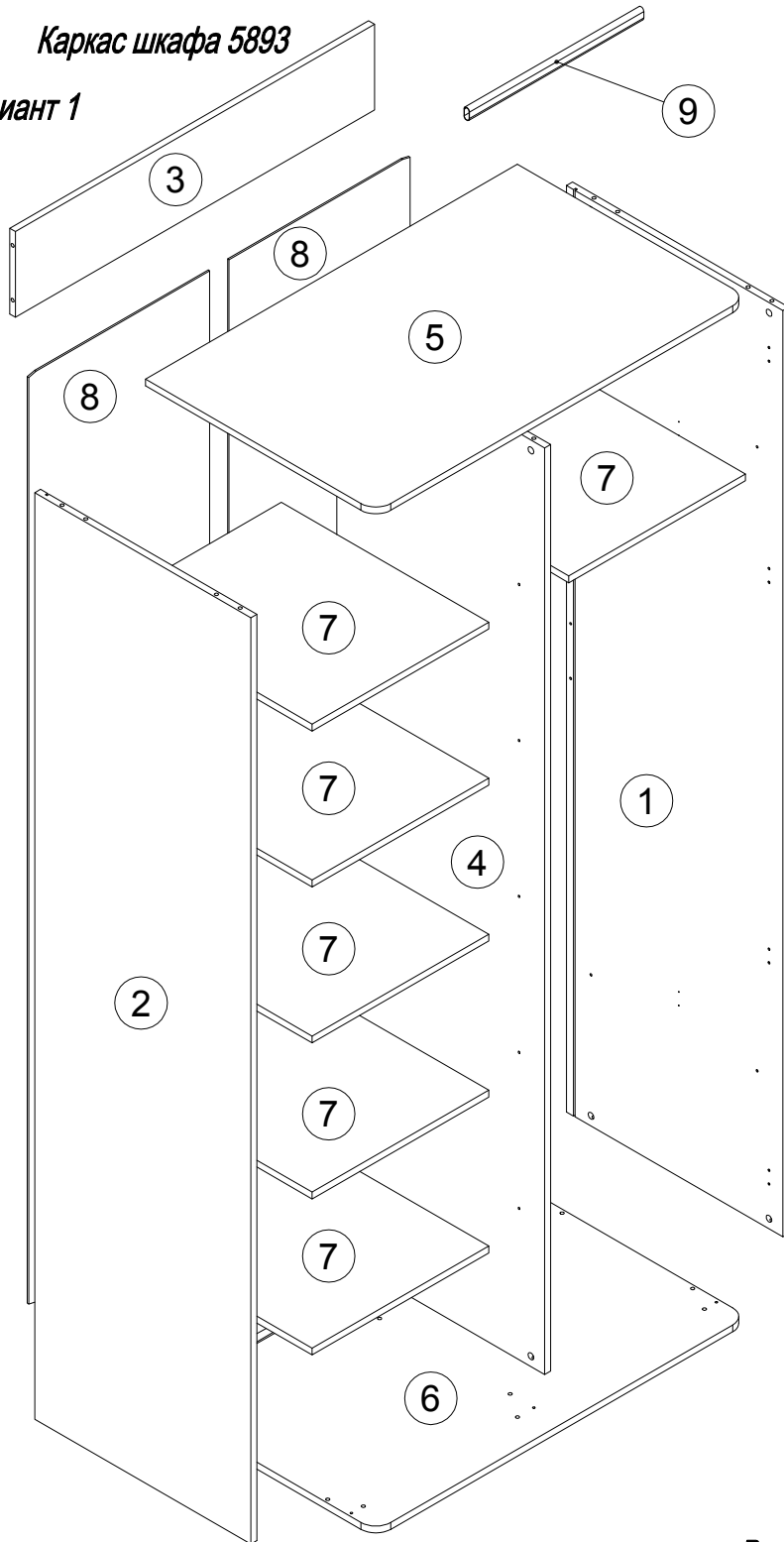

5895

5894

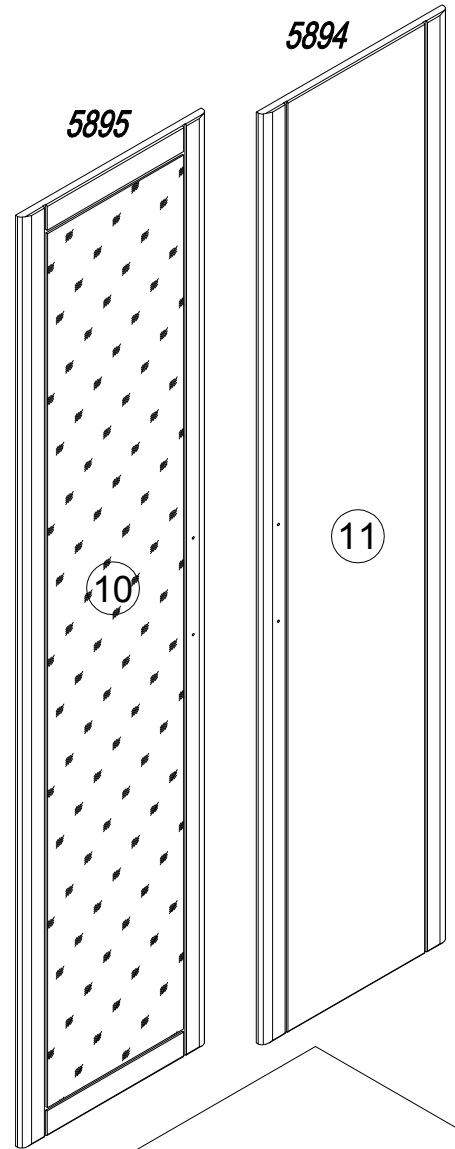

Вариант 2

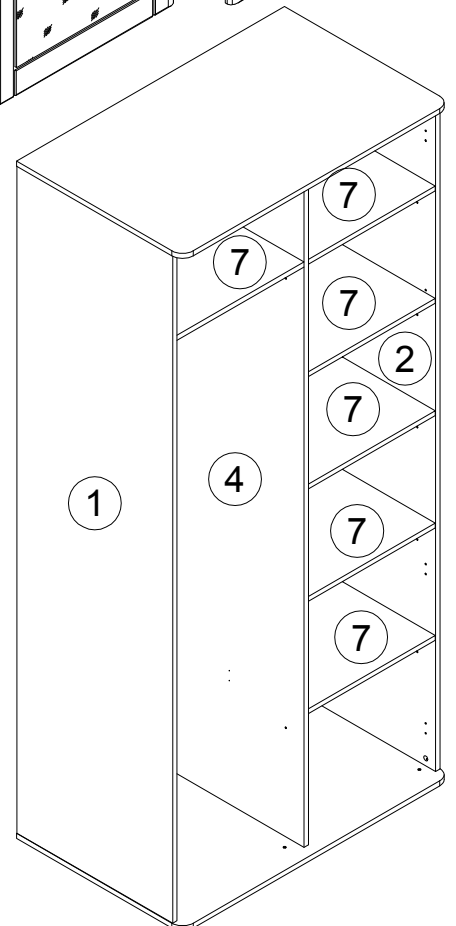

Каркас шкафа 5893

поз.	<i>наименование детали</i>	<i>№ упак.</i>	шт.	<i>длина, мм</i>	<i>ширина, мм</i>
1	Стенка боковая правая	2	1	2162	583
2	Стенка боковая левая	2	1	2162	583
3	Стенка задняя	1	1	968	200
4	Стенка-перегородка	3	1	2162	560
5	Стенка горизонтальная (крышка)	1	1	1002	621
6	Стенка горизонтальная (дно)	1	1	1002	621
7	Полка	1	6	476	559
8	Стенка задняя	3	2	2172	488
9	Штанга-труба	1	1	470	

Дверь шкафа с зеркалом 5895

поз.	<i>наименование детали</i>	<i>№ упак.</i>	шт.	<i>длина, мм</i>	<i>ширина, мм</i>
10	Дверь	1	1	2154	496







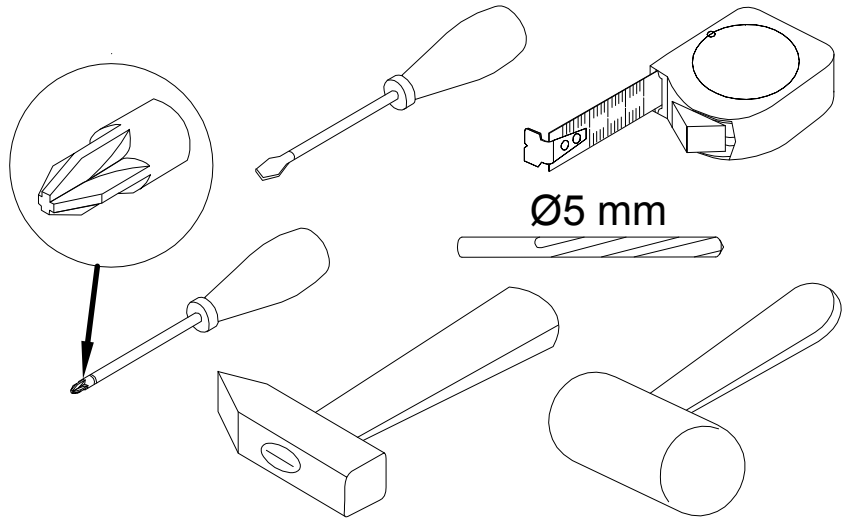
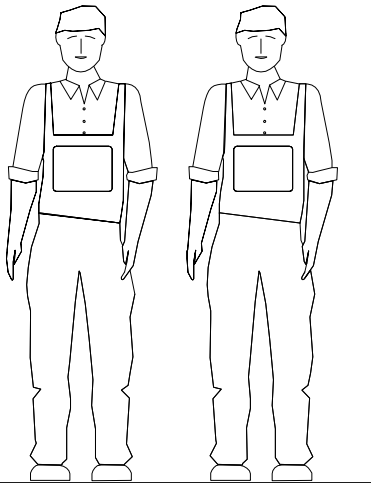









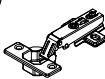



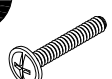

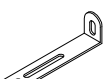
Дверь шкафа без зеркала 5894

поз.	<i>наименование детали</i>	<i>№ упак.</i>	шт.	<i>длина, мм</i>	<i>ширина, мм</i>
11	Дверь	1	1	2154	496

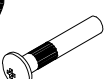

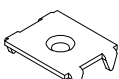

2

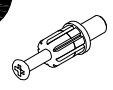

3

A 090913  7x32 x16	B 000146  15x12 x16	C 100640  20x0.5 x18	D 000151  8x35 x12	E 135021  x20	F 000759  3x20 x26
G 125913  x24	H 161423  x8	I 235594  6.3x16 x16	J 010942  4x16 x16	K 269594  x2	L 005960  M4x25 x4
M 007086  M6 x6	N 208693  M6x16 x6	O 155999  x1	P 000754  3.5x16 x2	Q 090185  4.5x45 x1	R 013859  8x40 x1
S 005145  M4x29 x2	T 000379  M4x16 x2	U 170390  x2	V 000762  3.5x13 x4	W 062367  x6	X 030579  x4

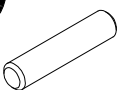
4

A 090913		7x32 x4	B 000146		15x12 x8	D 000151		8x35 x8	G 125913		x12
--------------------	--	-------------------	--------------------	--	--------------------	--------------------	--	-------------------	--------------------	--	------------

Для варианта 2 детали под №1,2
устанавливаются зеркально
приведенному

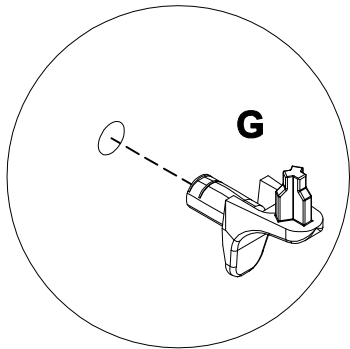
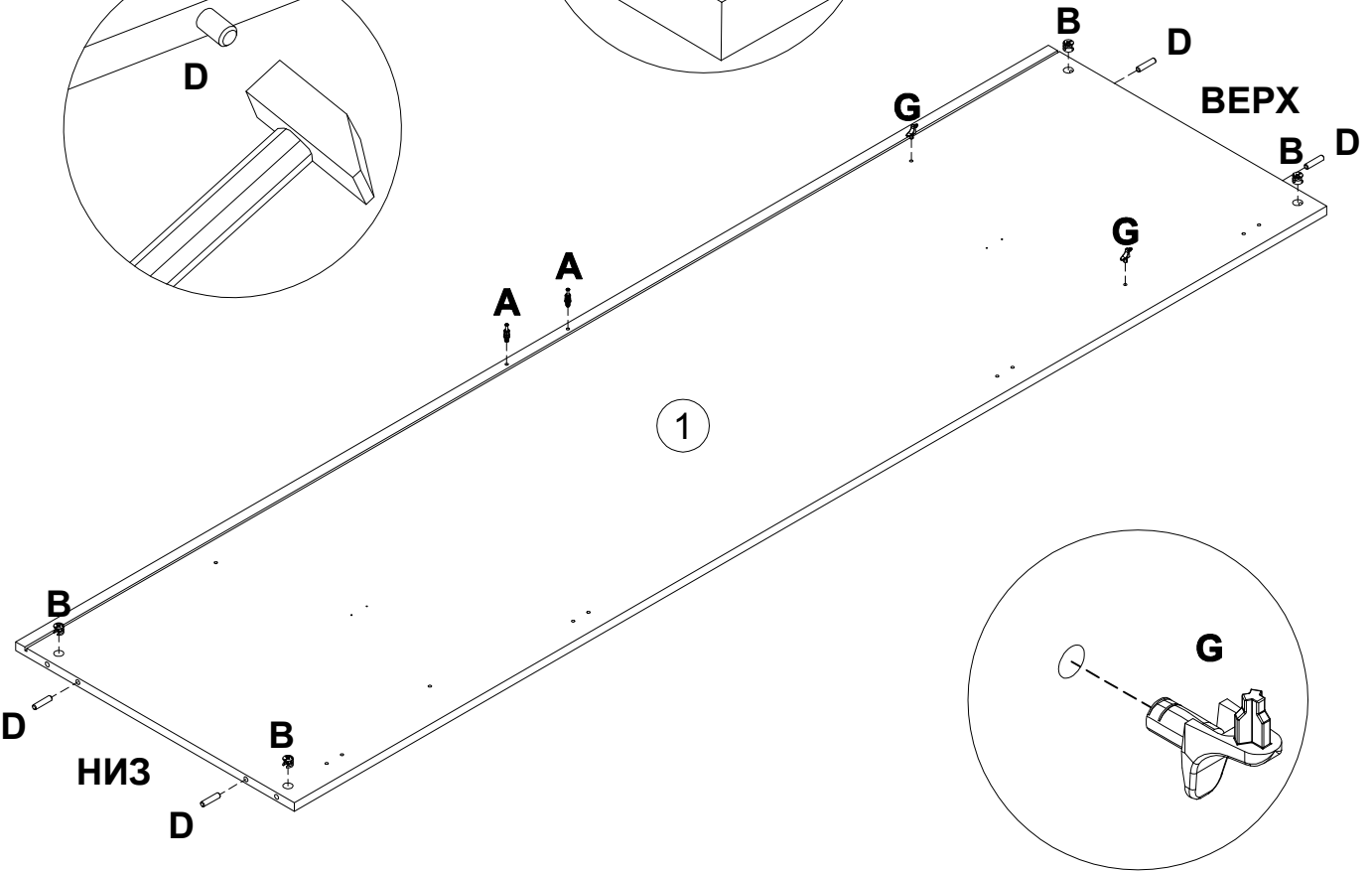
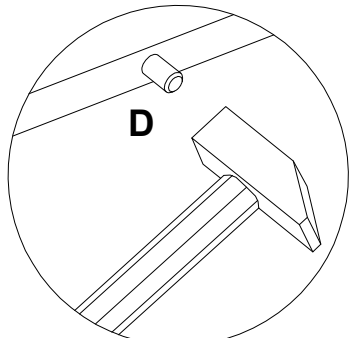
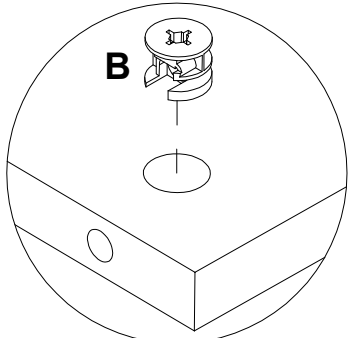
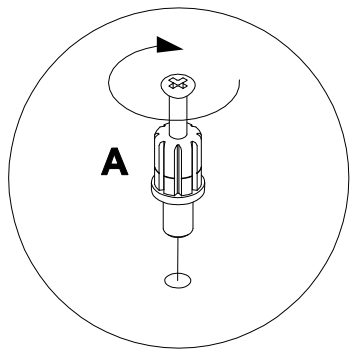
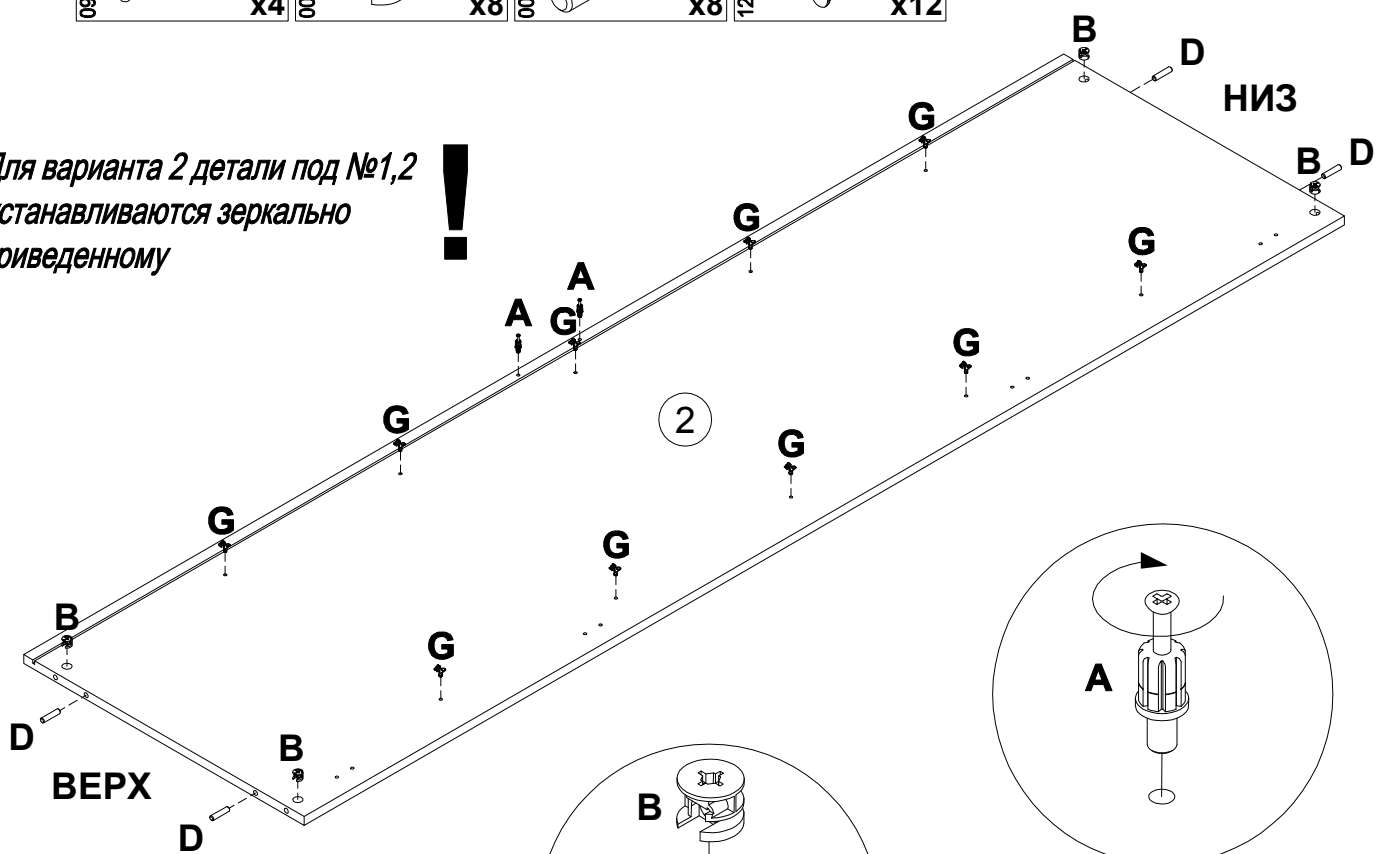

5

H
161423
x8

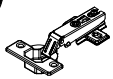

I
235594
x16



6.3x16
x16

U
170390
x1



x1

V
000762
x2



3.5x13
x2

Для варианта 2 детали под №1,2
устанавливаются зеркально
приведенному

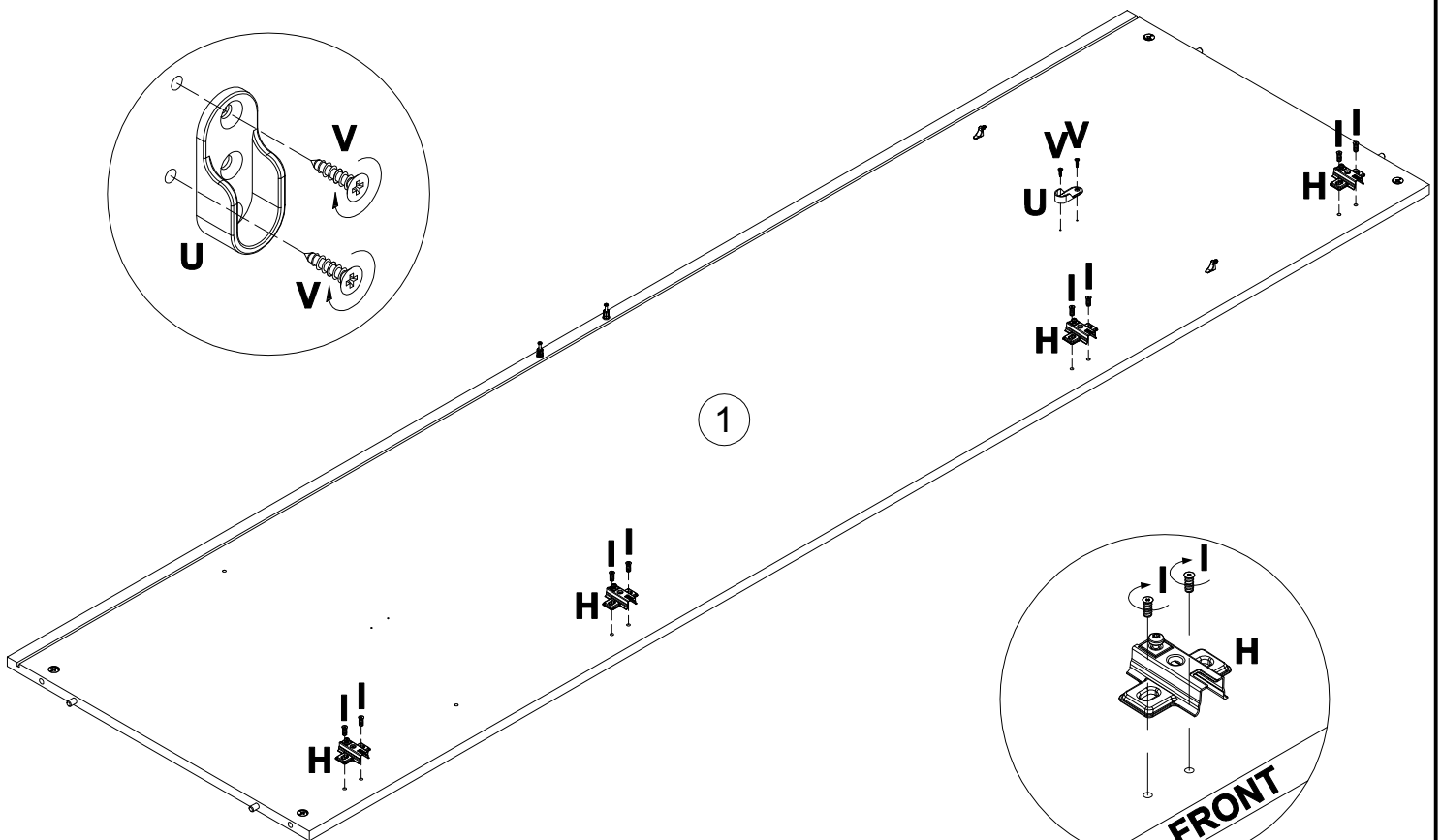
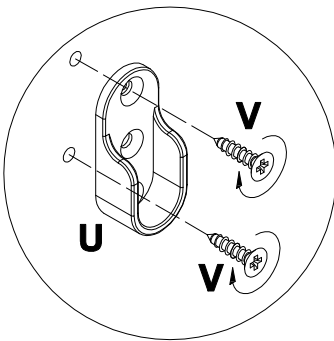
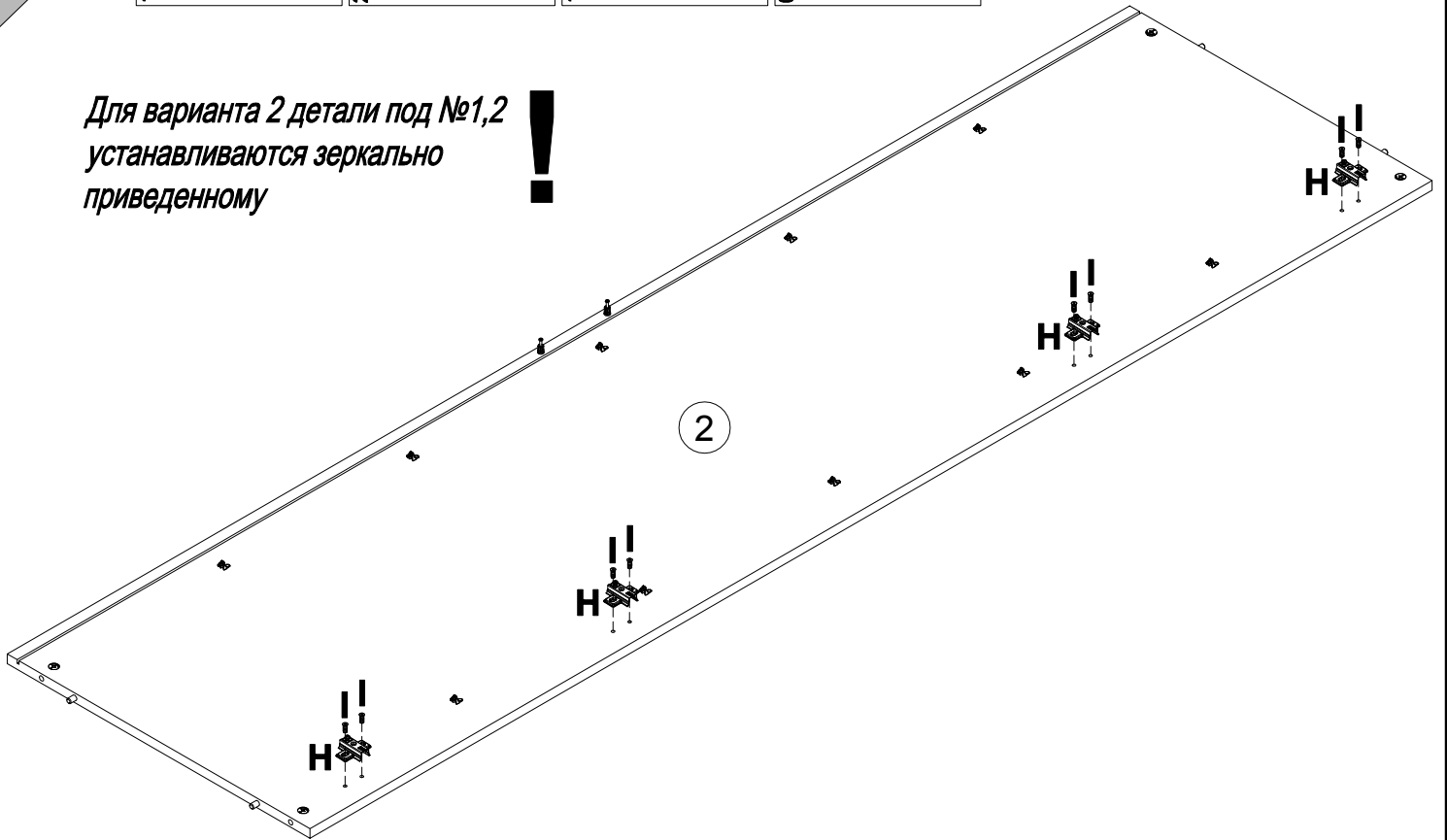

6

B
000146



15x12
x4

D
000151

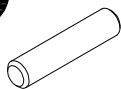

8x35
x4

G
125913



x12

U
170390



x1

V
000762



3.5x13
x2

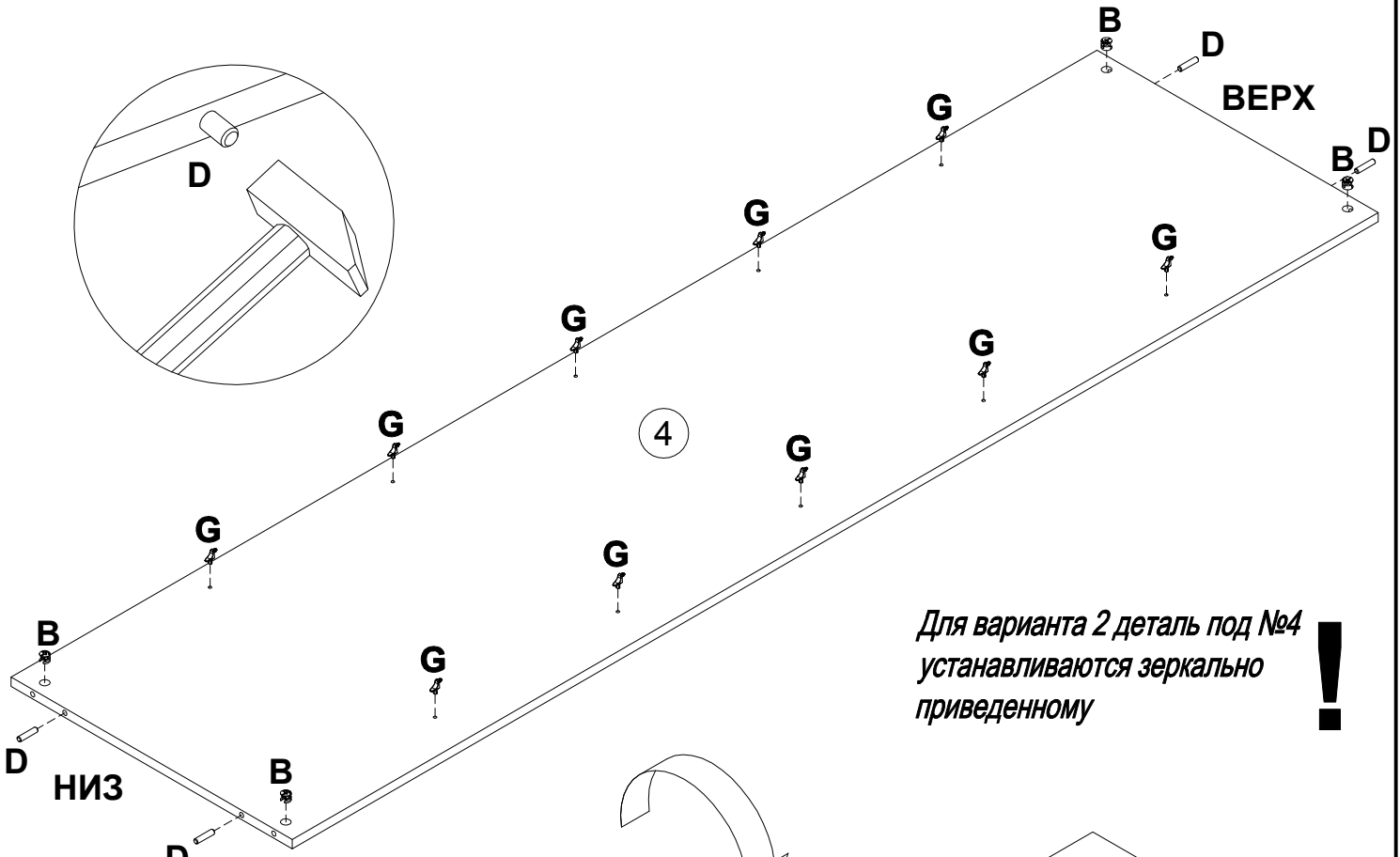

Для варианта 2 деталь под №4
устанавливаются зеркально
приведенному !

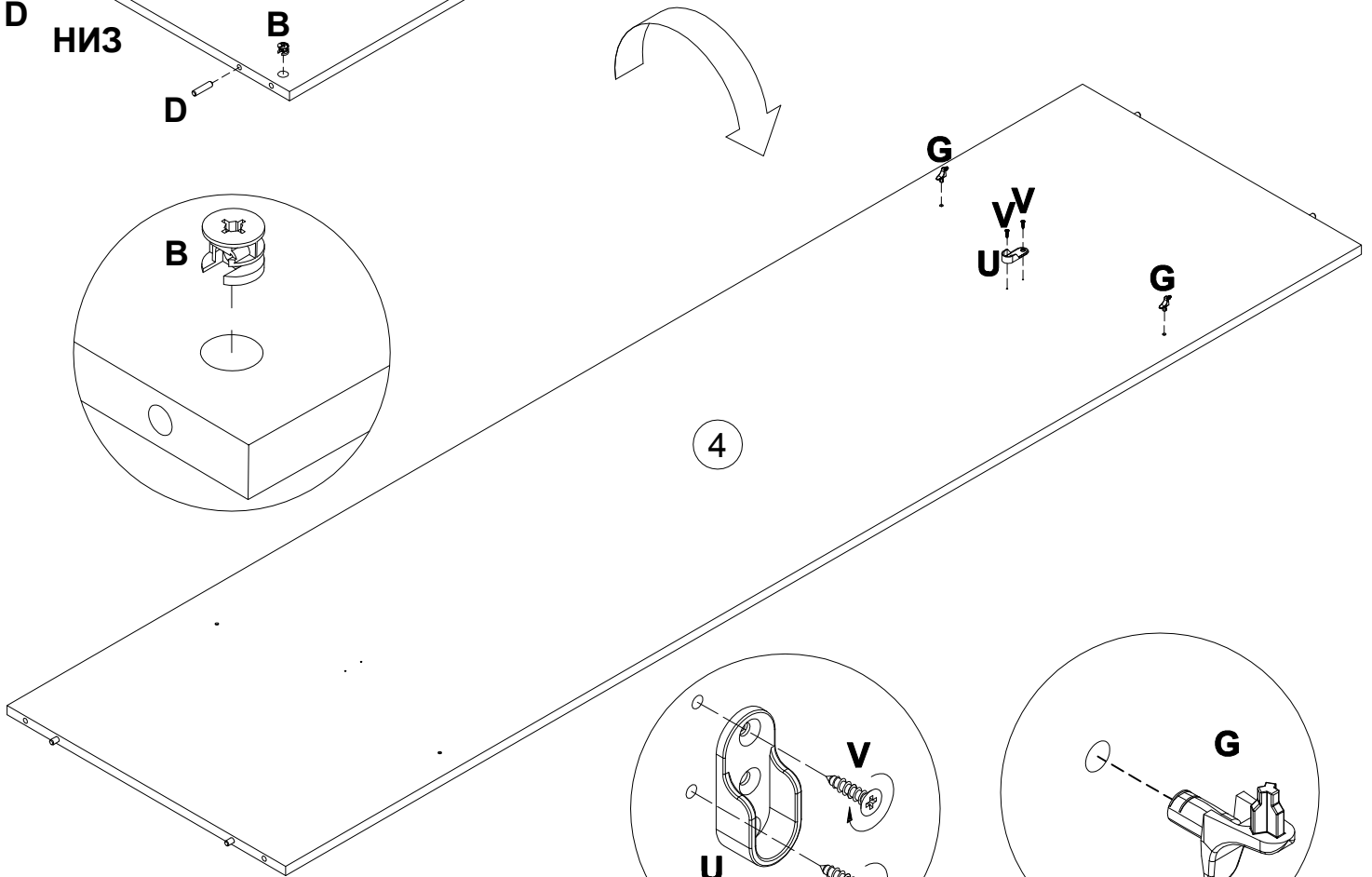

7

7

A	090913	7x32	x6
----------	--------	------	-----------

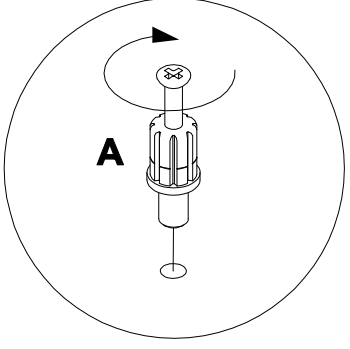
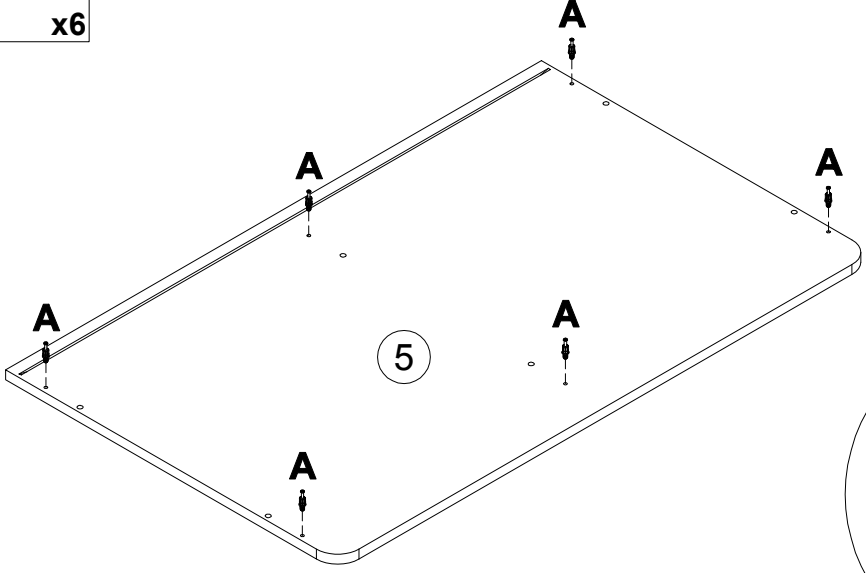

8

A	090913	7x32	x6	M	007086	M6	x6	N	208693	M6x16	x6
----------	--------	------	-----------	----------	--------	----	-----------	----------	--------	-------	-----------

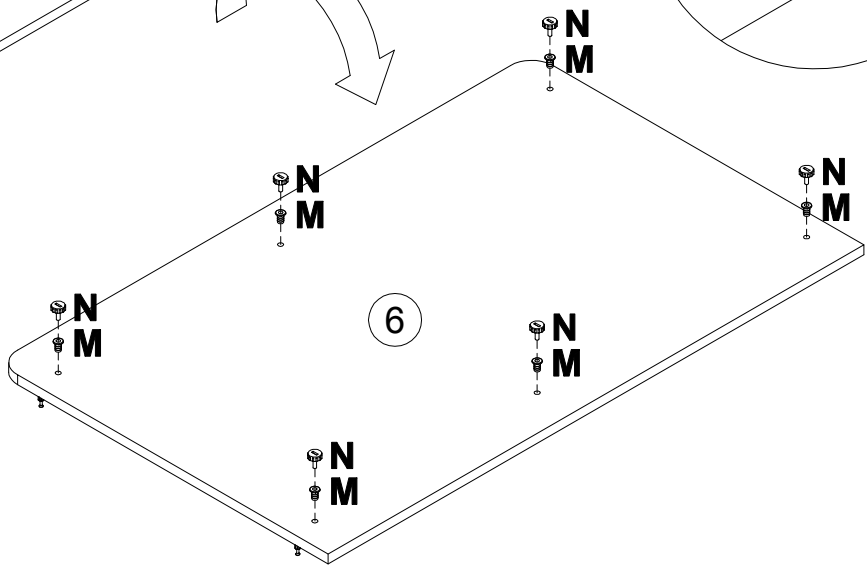
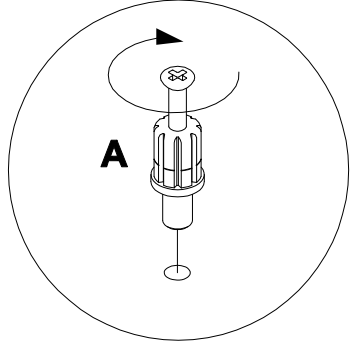
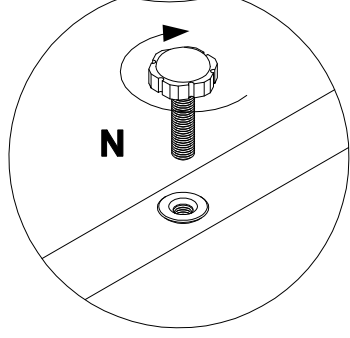
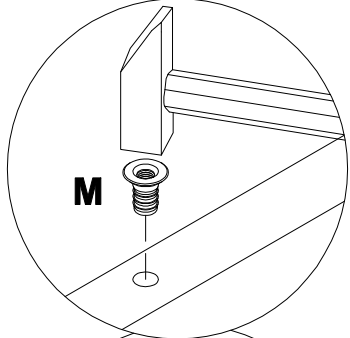
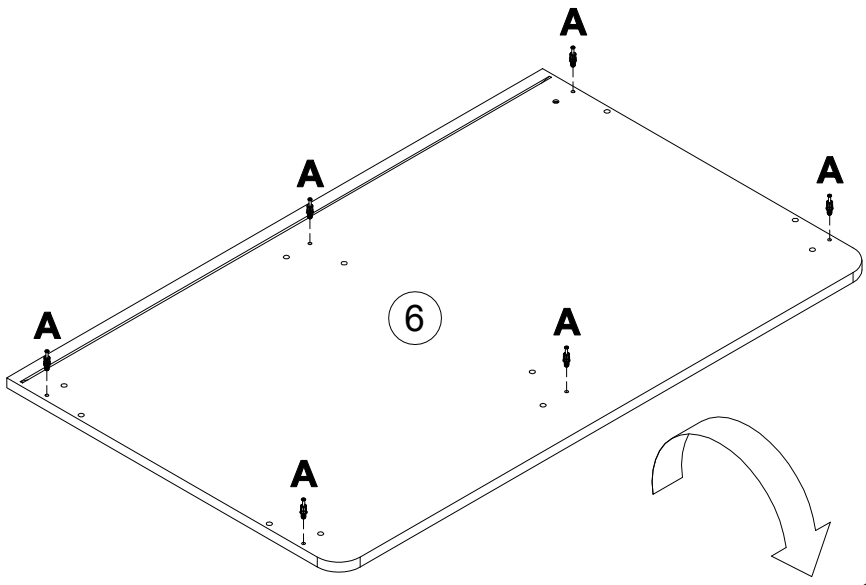

8

9

000146  15x12
x4

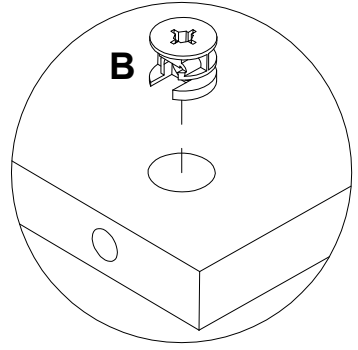
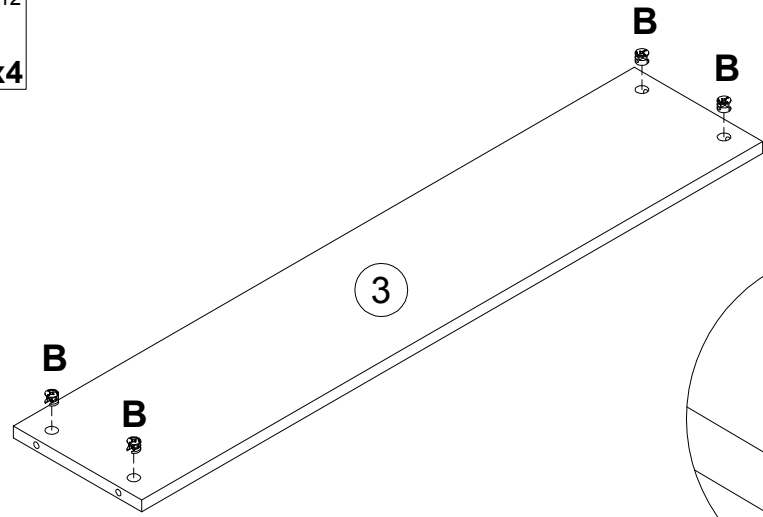

10

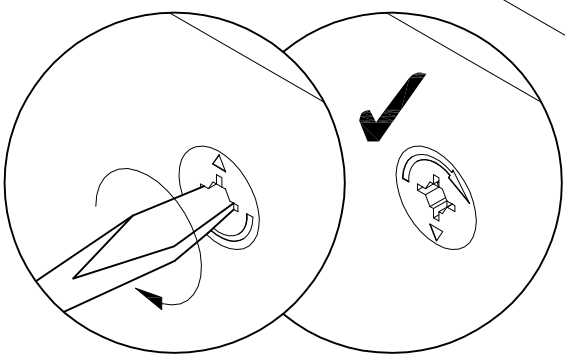
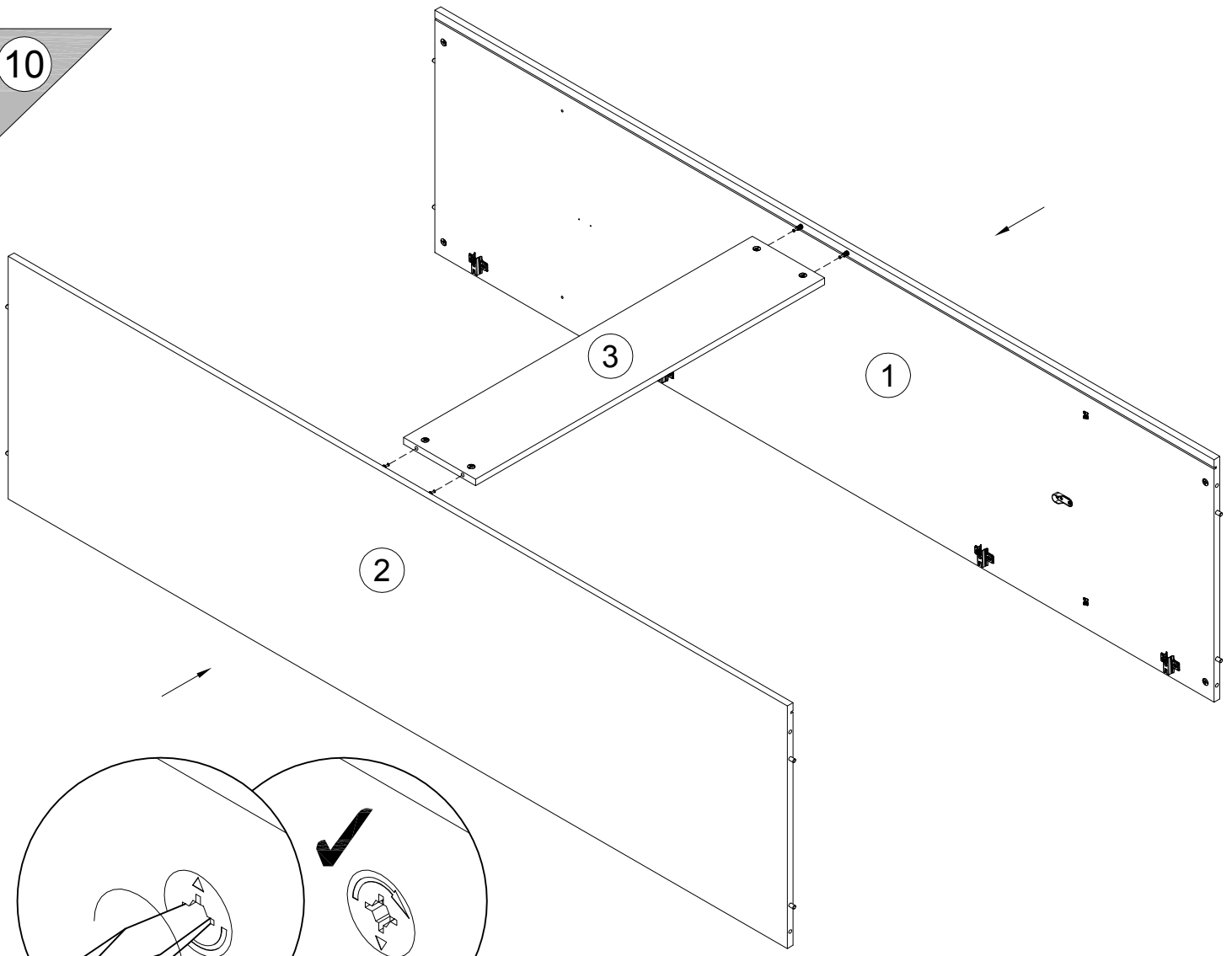

9

11

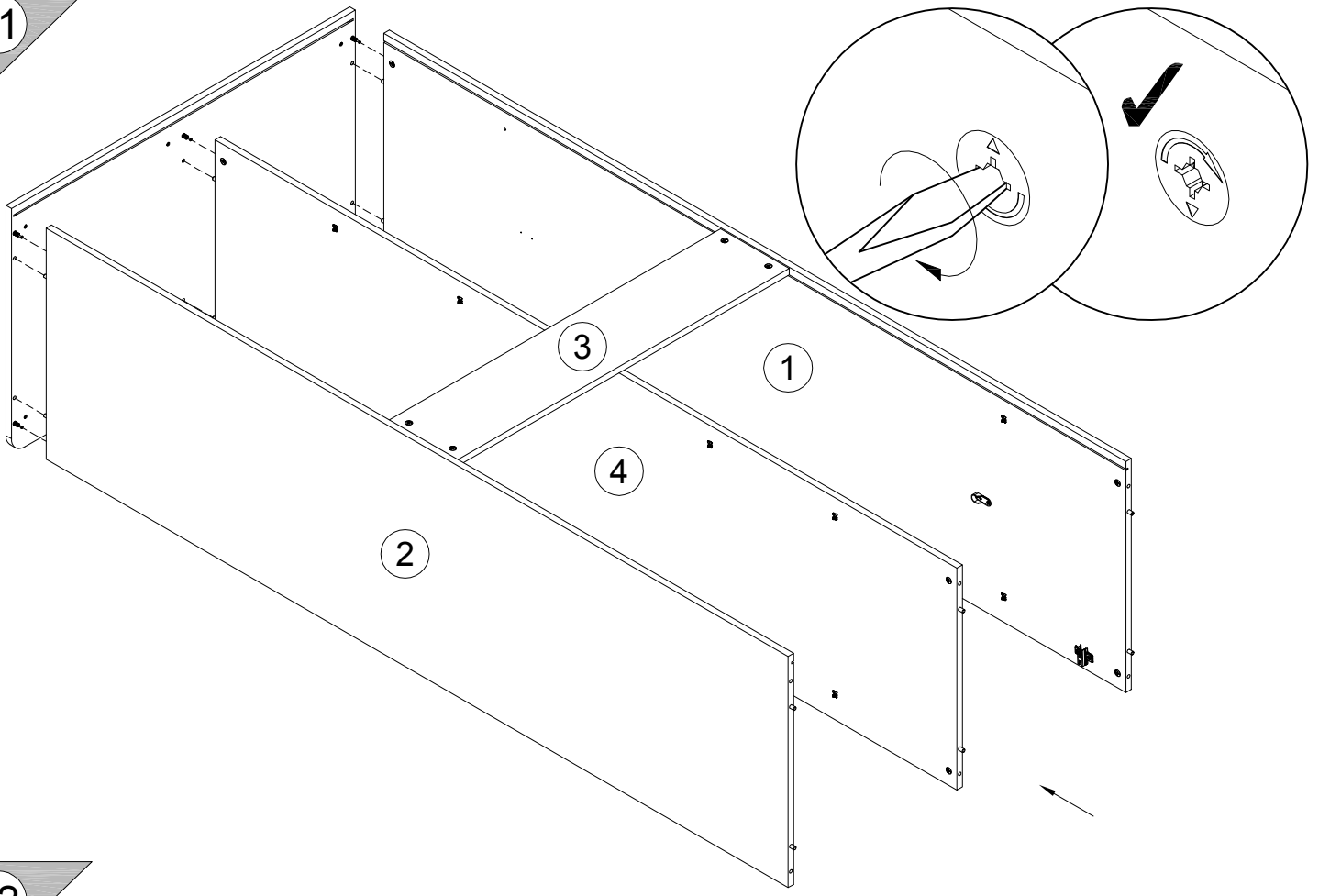

12

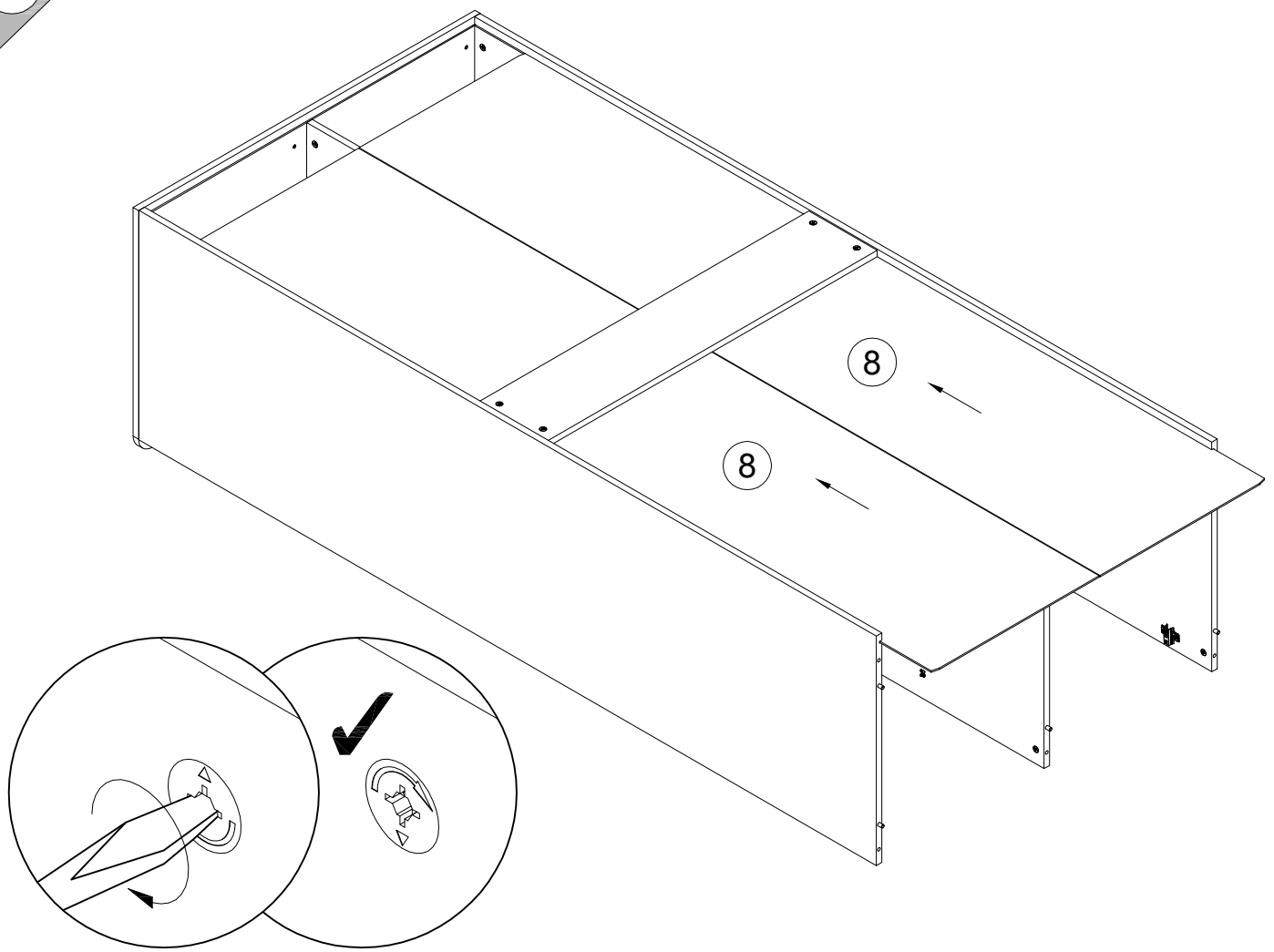

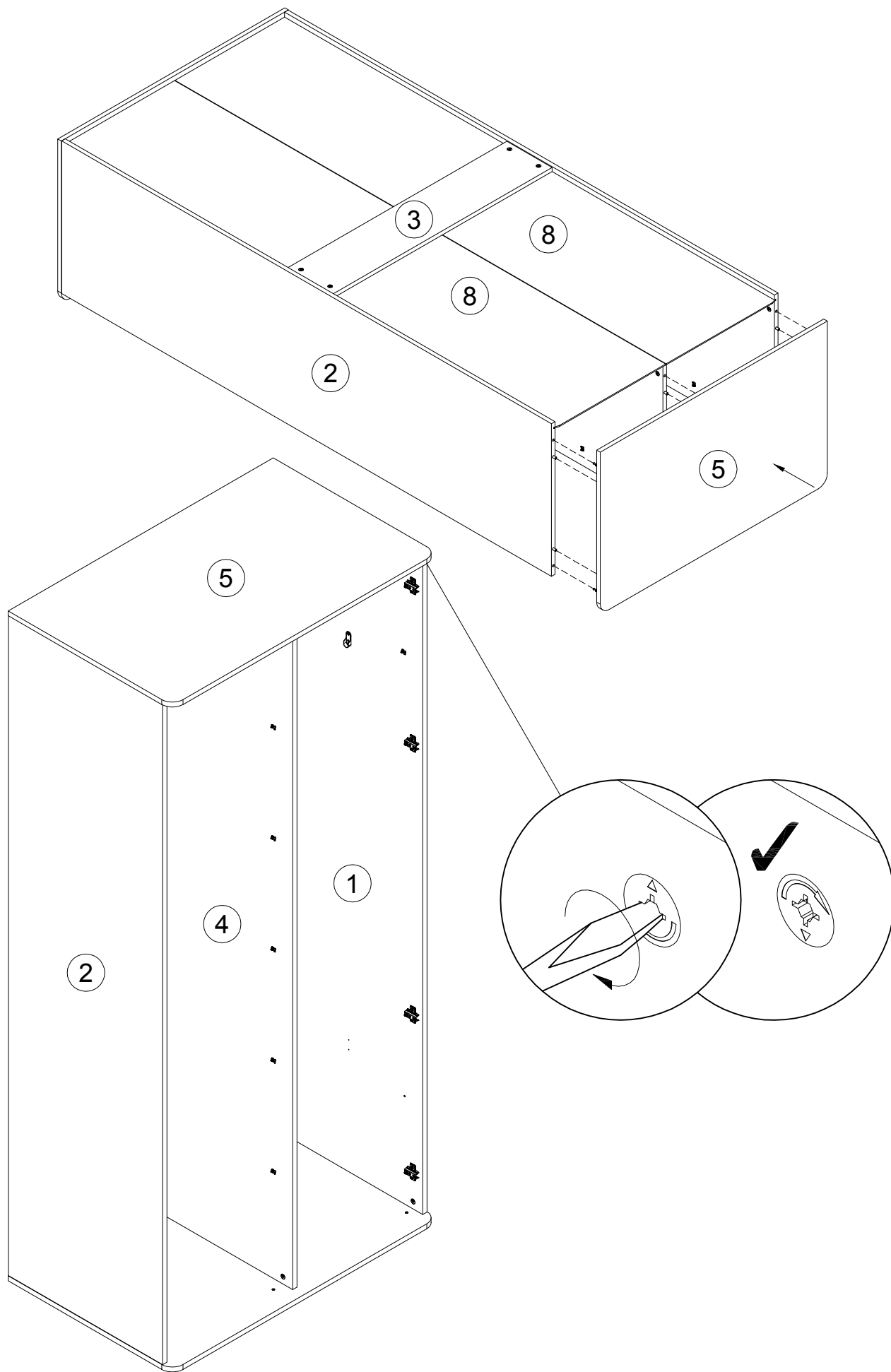

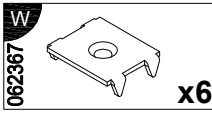
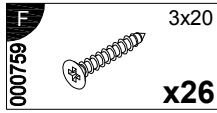
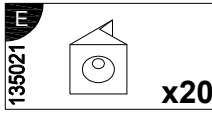

14

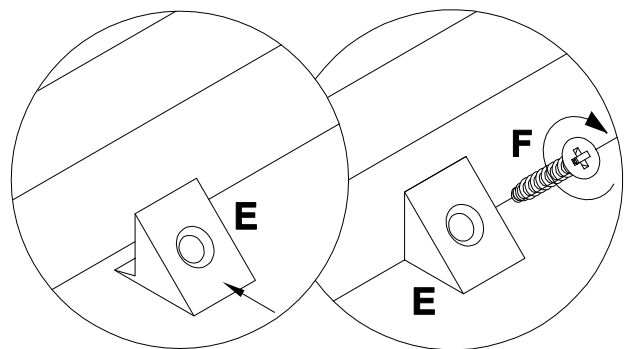
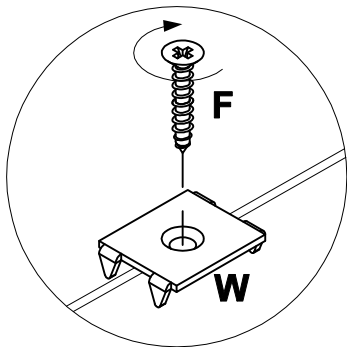
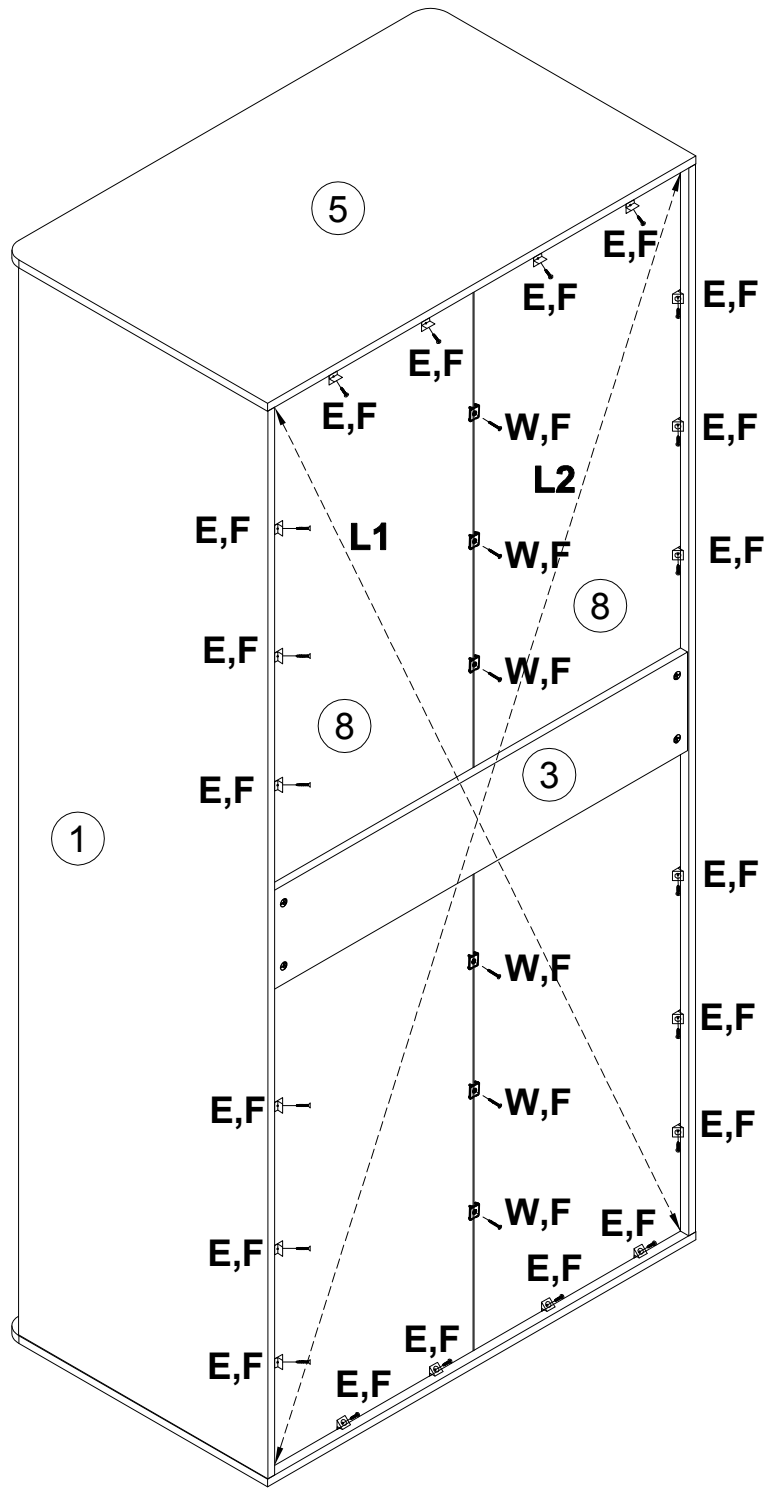

L1=L2



15

030579 X

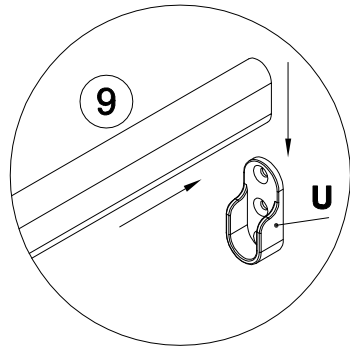
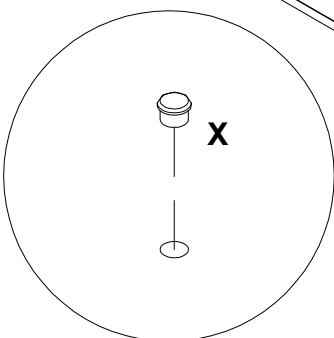
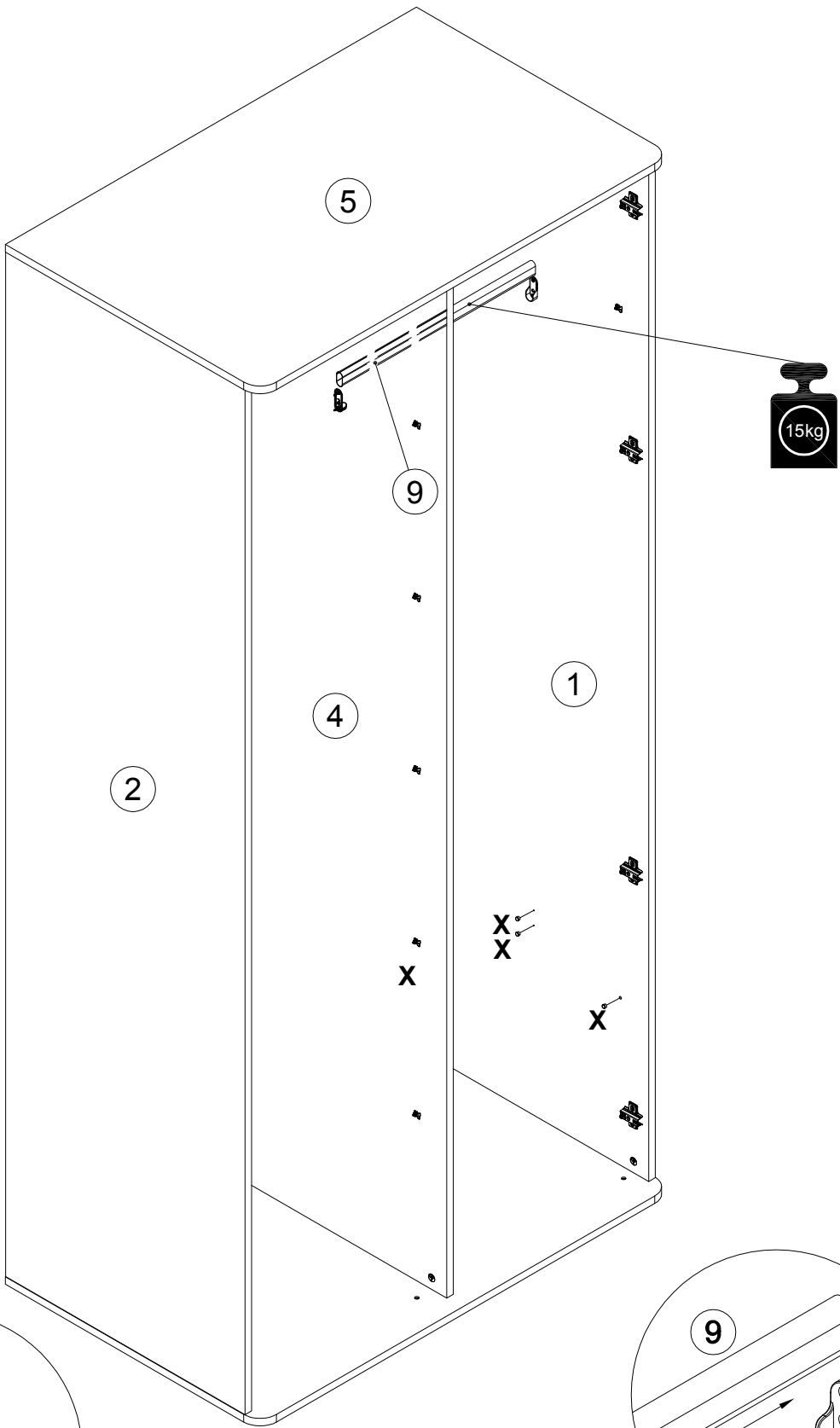
x4



16

C 100640 20x0.5 x18

O 155999 x1

P 000754 3.5x16 x2

Q 090185 4.5x45 x1

R 013859 8x40 x1

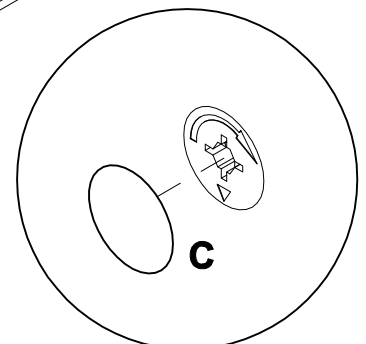
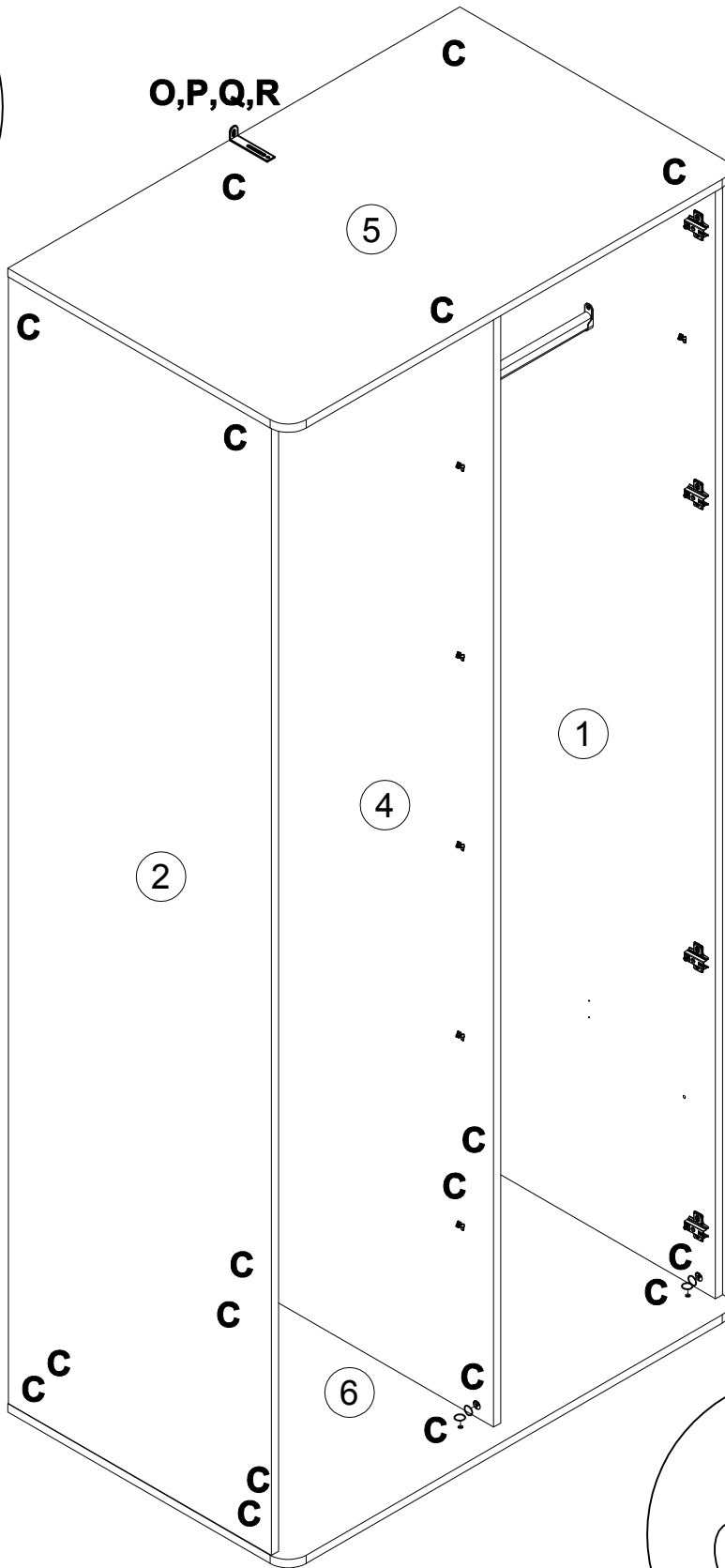
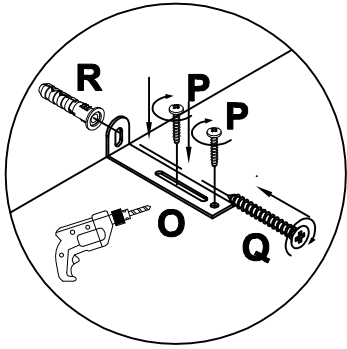

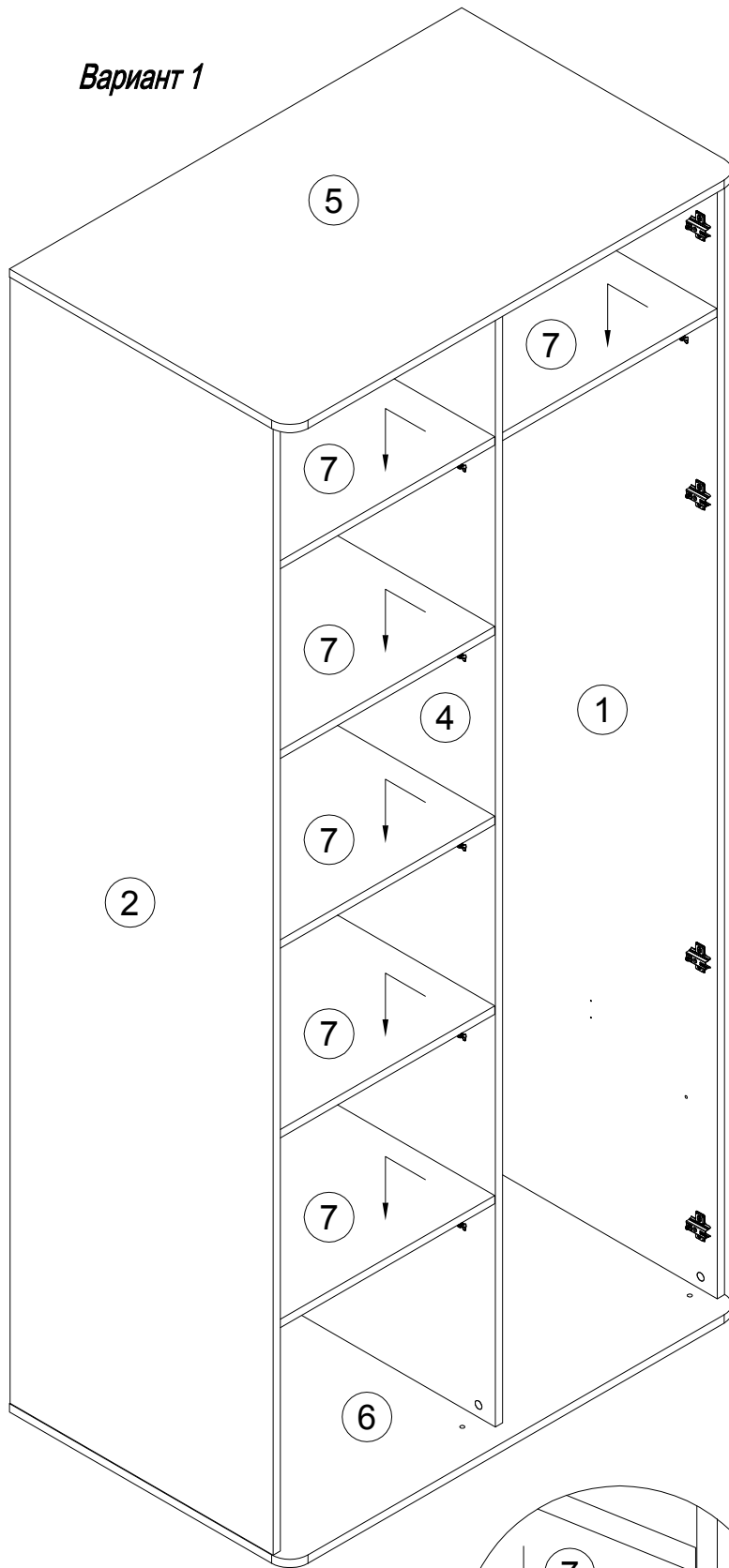

Вариант 1

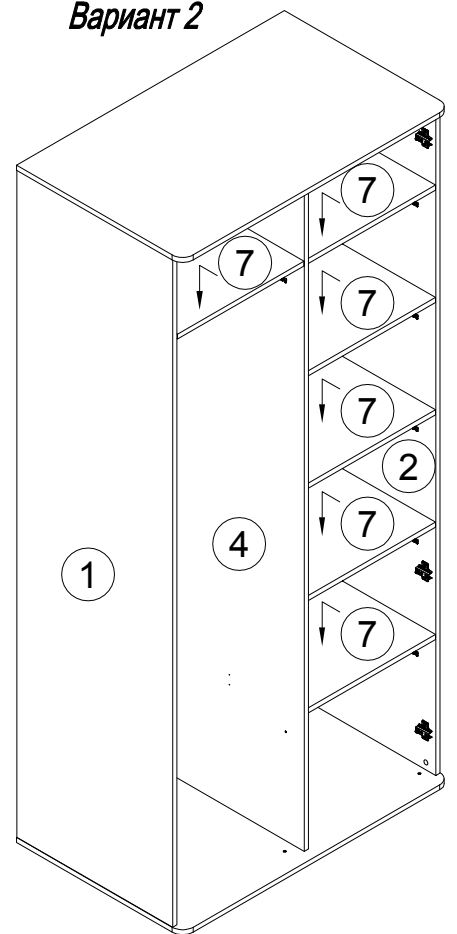

Вариант 2



- | | |
|---|---|
| 
005145 S
M4x29
x2 | 
000379 T
M4x16
x2 |
|---|---|

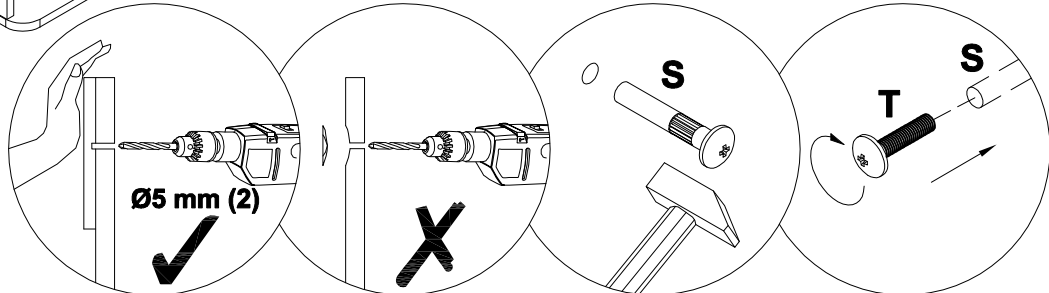
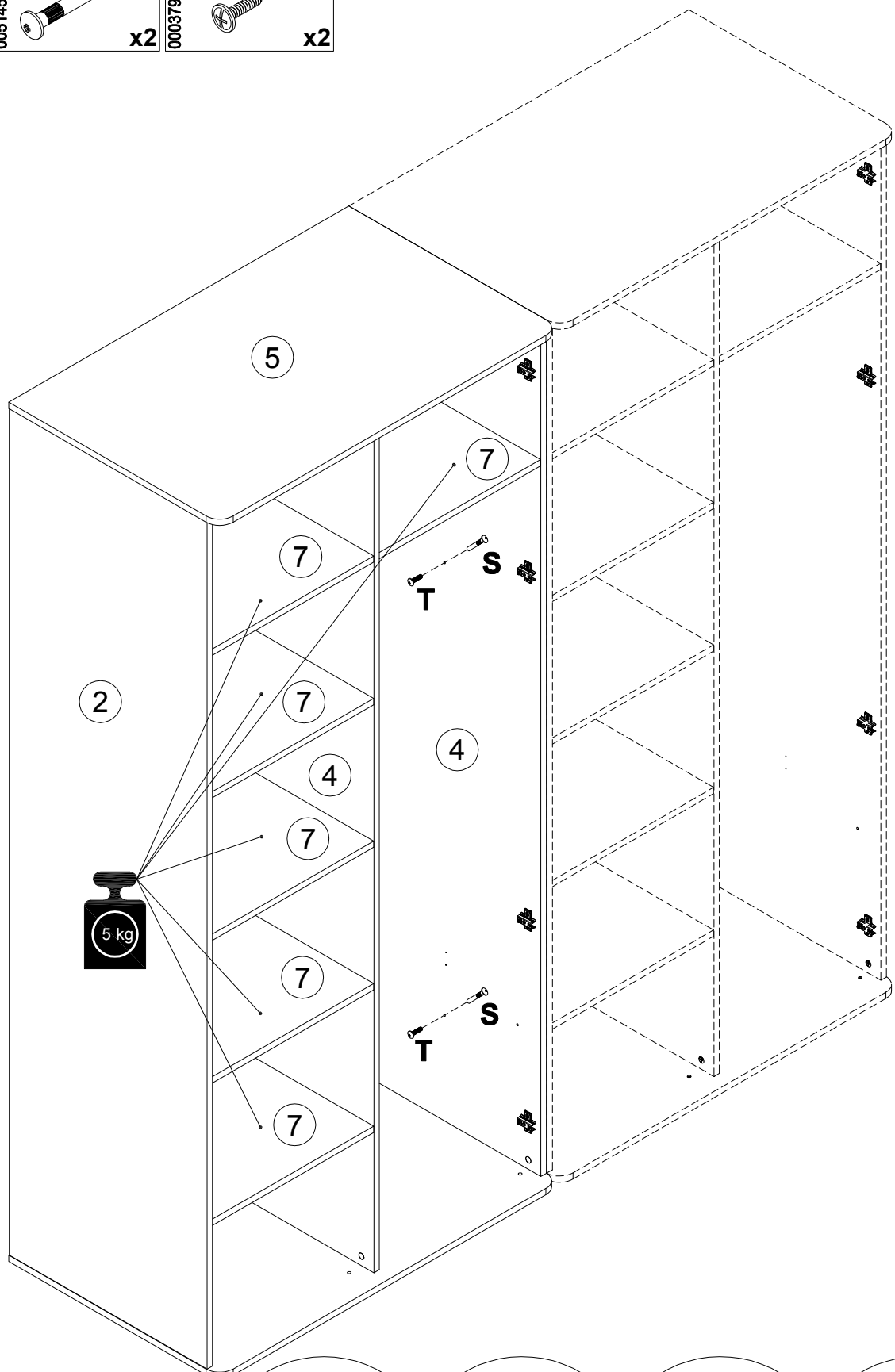

19

- H** 161423 x8
- J** 010942 4x16 x16
- K** 269594 x2
- L** 005960 M4x25 x4

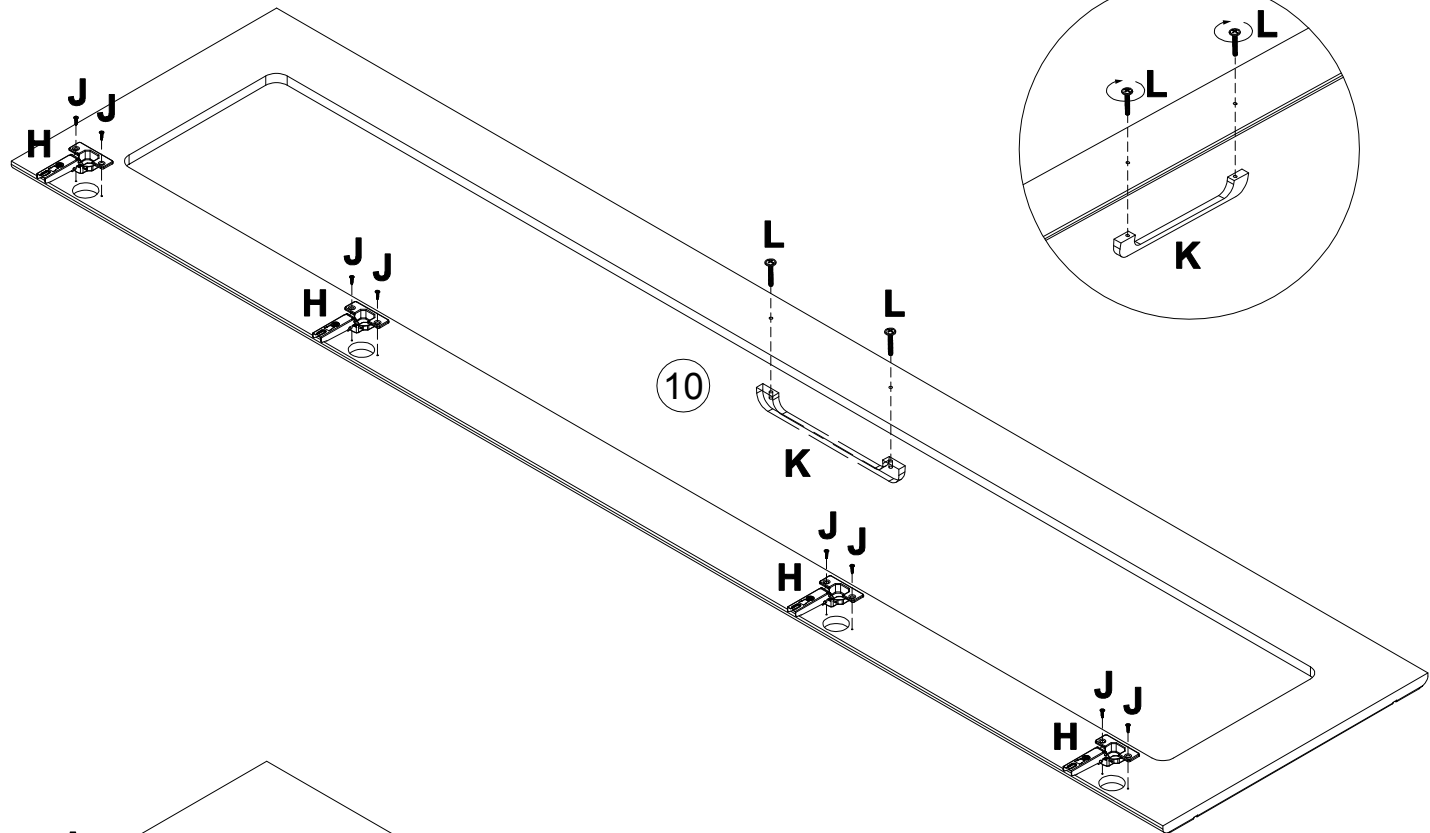

10

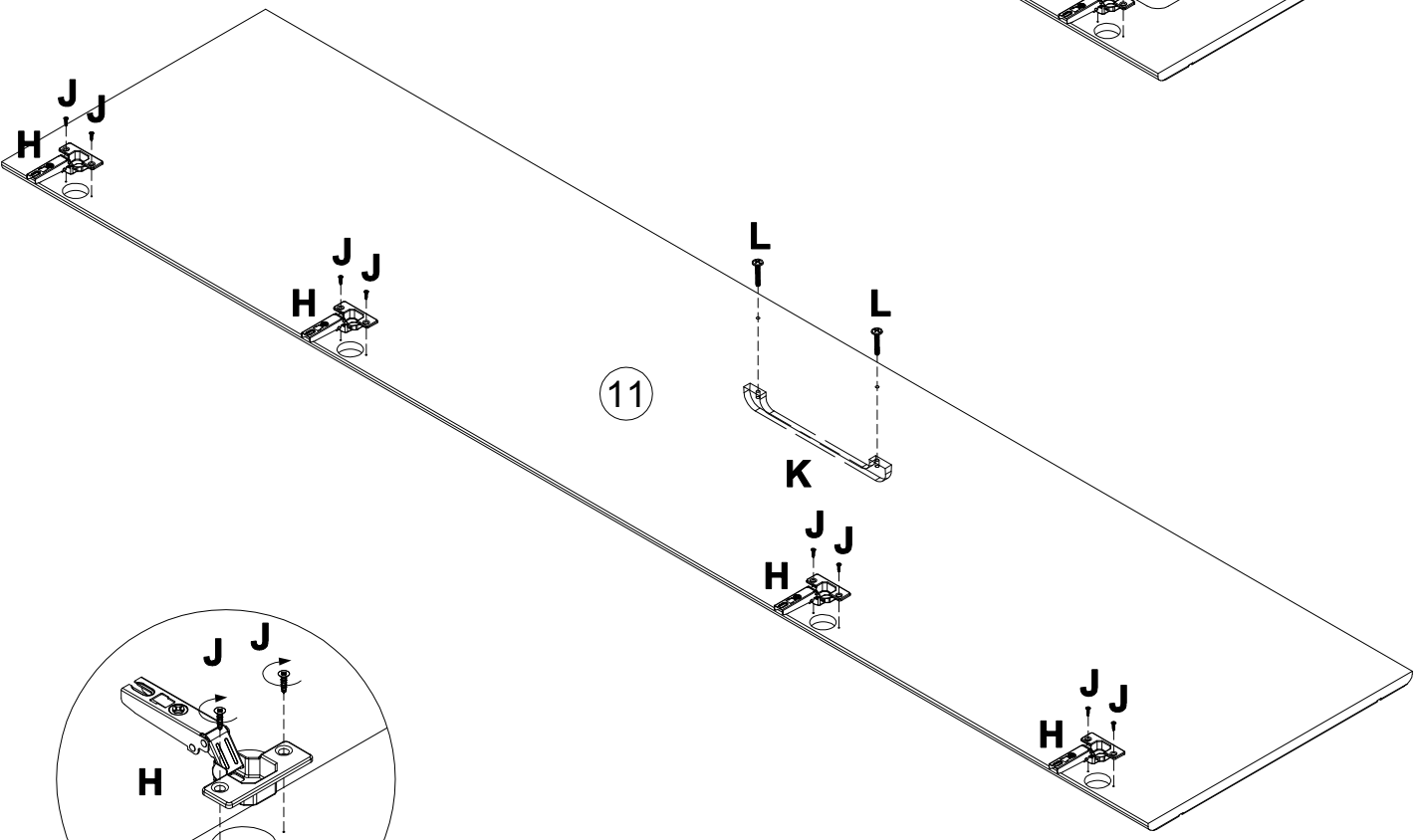

11

20

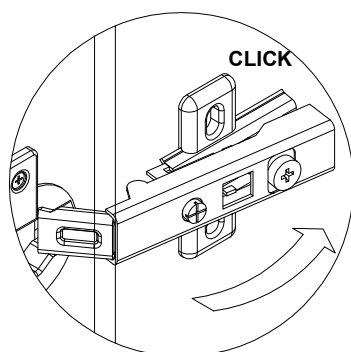
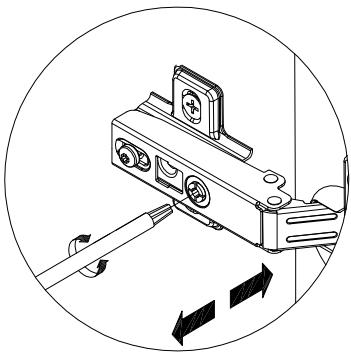
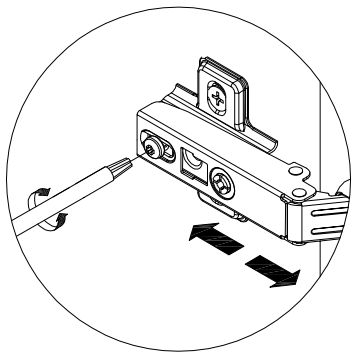
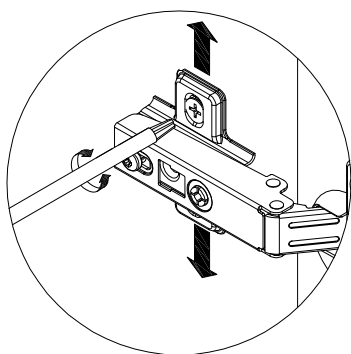
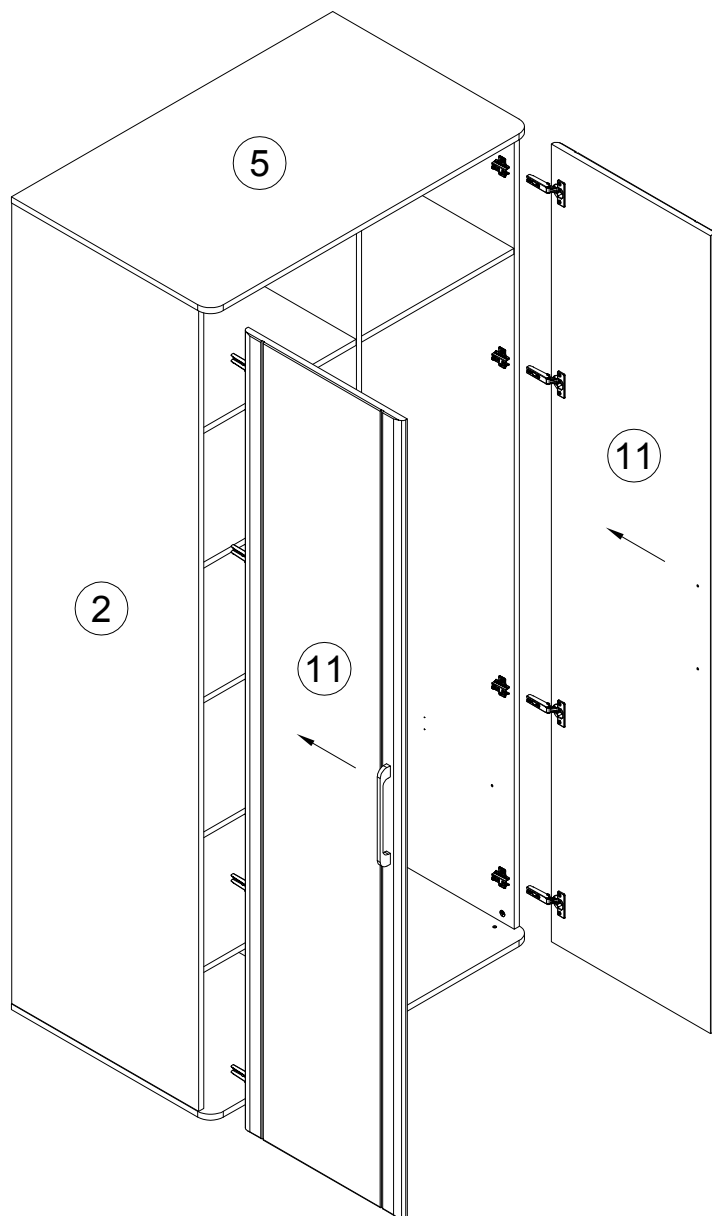
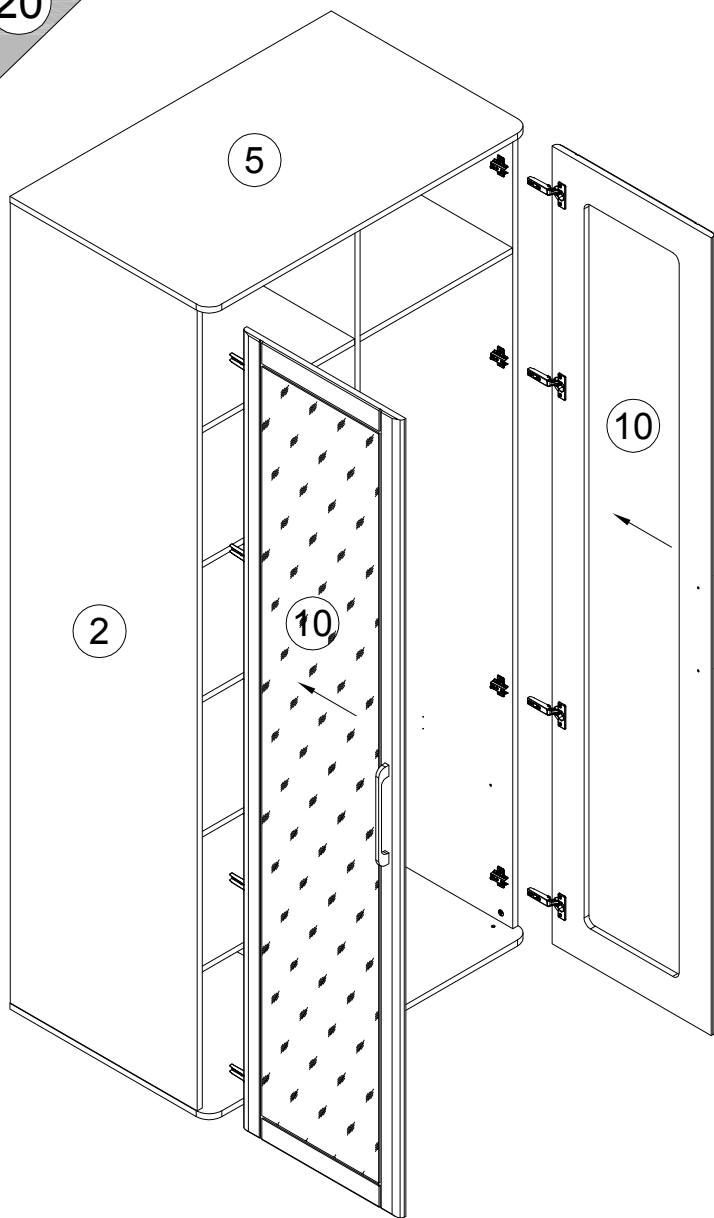

Инструкция по уходу за мебелью и правила эксплуатации

1. Мебель рекомендуется эксплуатировать в бытовых помещениях с температурой воздуха не ниже +2 °С и относительной влажностью 45-70%.
2. Мебель должна быть защищена от воздействия прямых солнечных лучей, так как это вредит внешнему виду изделий и может изменить цвет поверхности.
3. Не следует ставить на поверхность мебели горячие предметы.
4. Случайно попавшую на поверхность изделия влагу, жидкость следует снять сухой тканью.
5. Удаление пыли с полированной или лакированной поверхности следует производить сухой тканью (фланель, миткаль).
6. Полированные и лакированные поверхности мебели рекомендуется освежать специально предназначенными для этого средствами.
7. Очищать стекла рекомендуется специальными составами, нанесенными на мягкую ткань.
8. Не допускается применение соды, стиральных порошков, абразивных паст, порошков и прочих, не предназначенных для ухода за изделиями мебели препаратов.

В связи с постоянной работой, направленной на улучшение потребительских свойств мебели, предприятие-изготовитель оставляет за собой право на изменения конструкции, не влияющие на качество и внешний вид изделия.