

EAC

инструкция по сборке

Шкаф двухдверный арт. 6980 левый

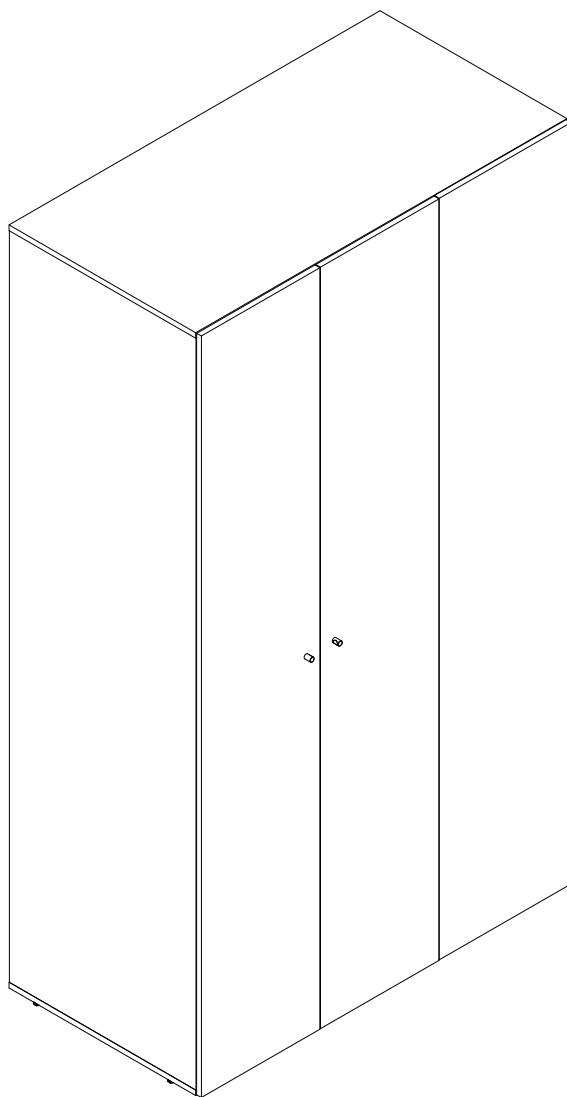

габаритные размеры

высота - 2218 мм

ширина - 1240 мм

глубина - 640 мм

единая справочная служба:

8 800 100-50-22

(звонок по России бесплатный)

LAZURIT
FURNITURE FACTORY

1

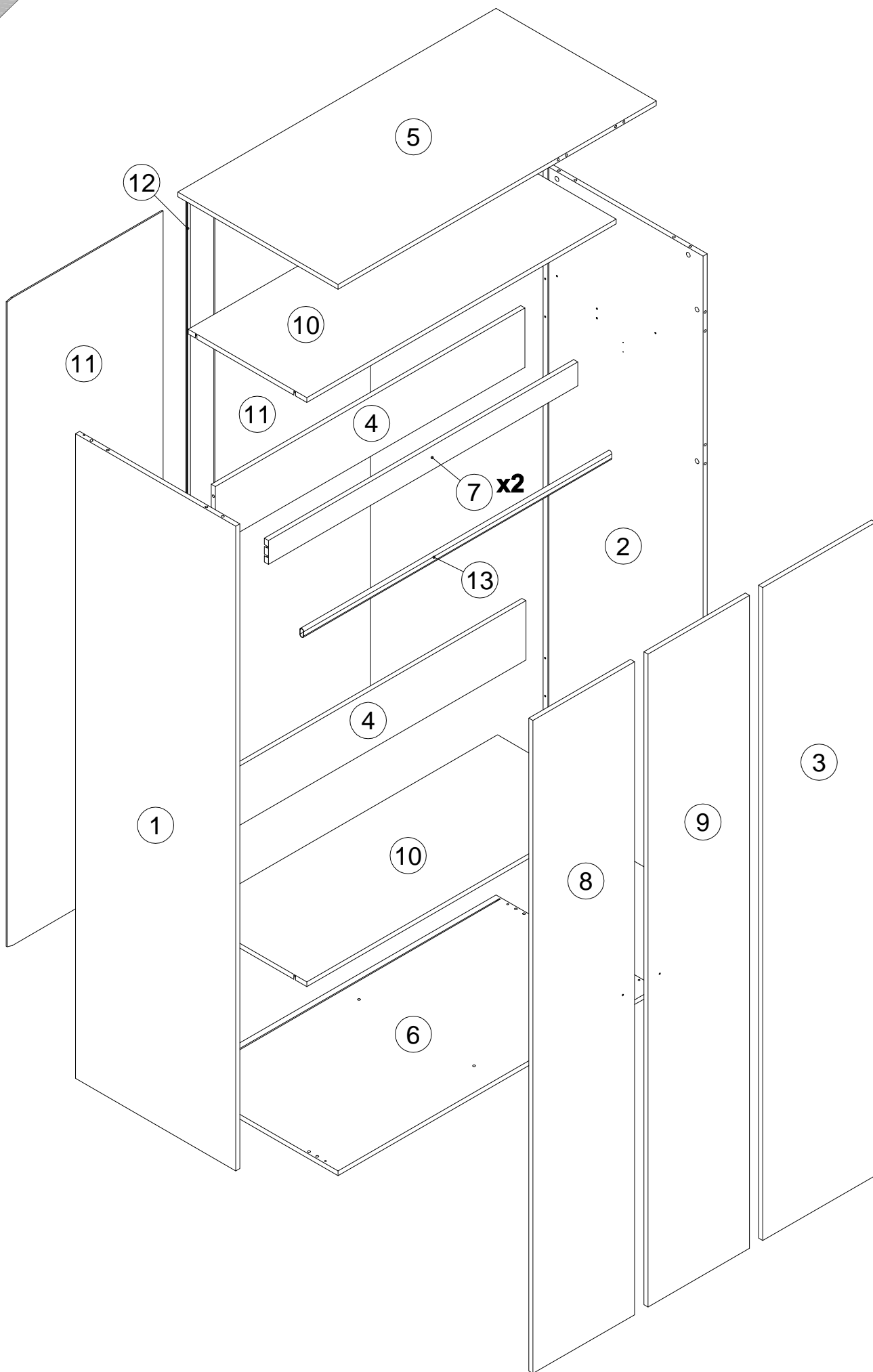

поз.	наименование детали	№ упак.	шт.	длина, мм	ширина, мм
1	Стенка боковая	3	1	2176	624
2	Стенка боковая	3	1	2176	624
3	Стенка передняя	2	1	2204	440
4	Стенка задняя	1	2	1206	200
5	Стенка горизонтальная	1	1	1240	624
6	Стенка горизонтальная	1	1	1240	624
7	Стенка вертикальная	1	2	1206	80
8	Дверь	2	1	2204	396
9	Дверь	2	1	2204	396
10	Полка	1	2	1206	462
11	Стенка задняя	3	2	2186	607
12	Планка	2	1	2174	
13	Штанга-труба	1	1	1201	

3

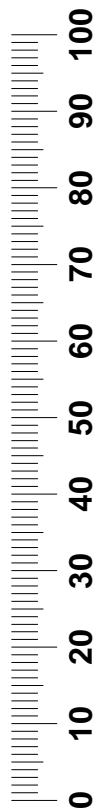
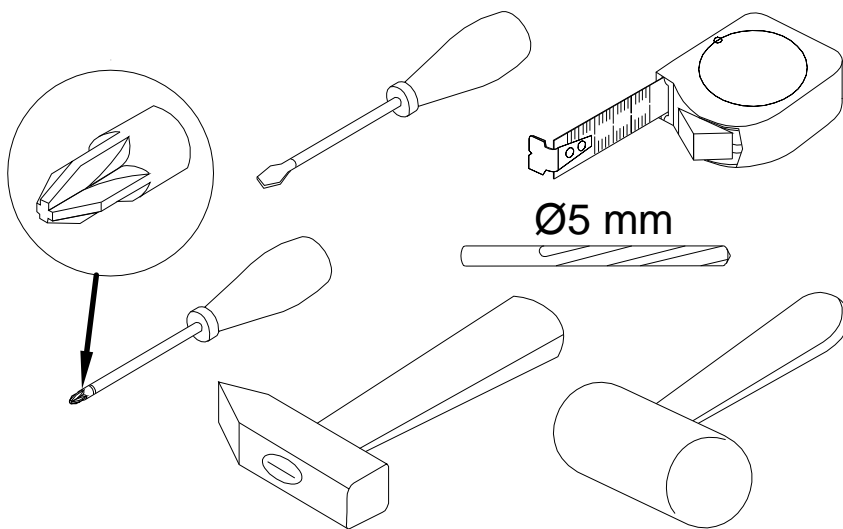
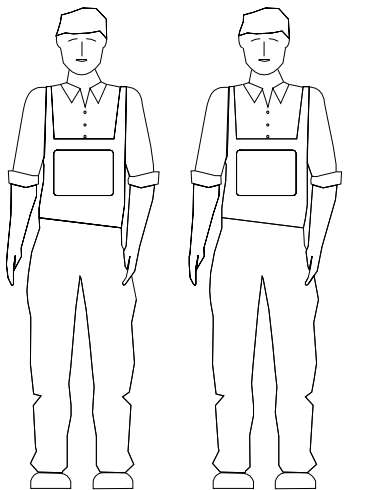

4

A 090913 7x32 x24	B 000146 15x12 x24	C 100640 20x0.5 x24	D 000151 8x35 x16	E 007086 M6 x6	F 208693 M6x16 x6
G 155999 x1	H 000754 3.5x16 x2	I 090185 4.5x45 x1	J 013859 8x40 x1	K 005145 M4x29 x2	L 000379 M4x16 x2
M 135021 x20	N 000759 3x20 x20	O 161423 x4	P 318975 x4	Q 235594 6.3x16 x16	R 010942 4x16 x16
S 310591 x2	T 002704 M4x20 x2	U 092070 x16	V 009956 x16	W 170390 x2	X 000762 3.5x13 x4

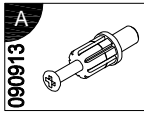

7x32
x8

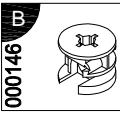

15x12
x12

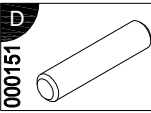

8x35
x12

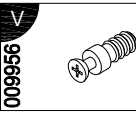

009956
x16



170390
x2

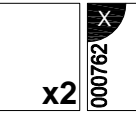

000762
x4

3.5x13
x4

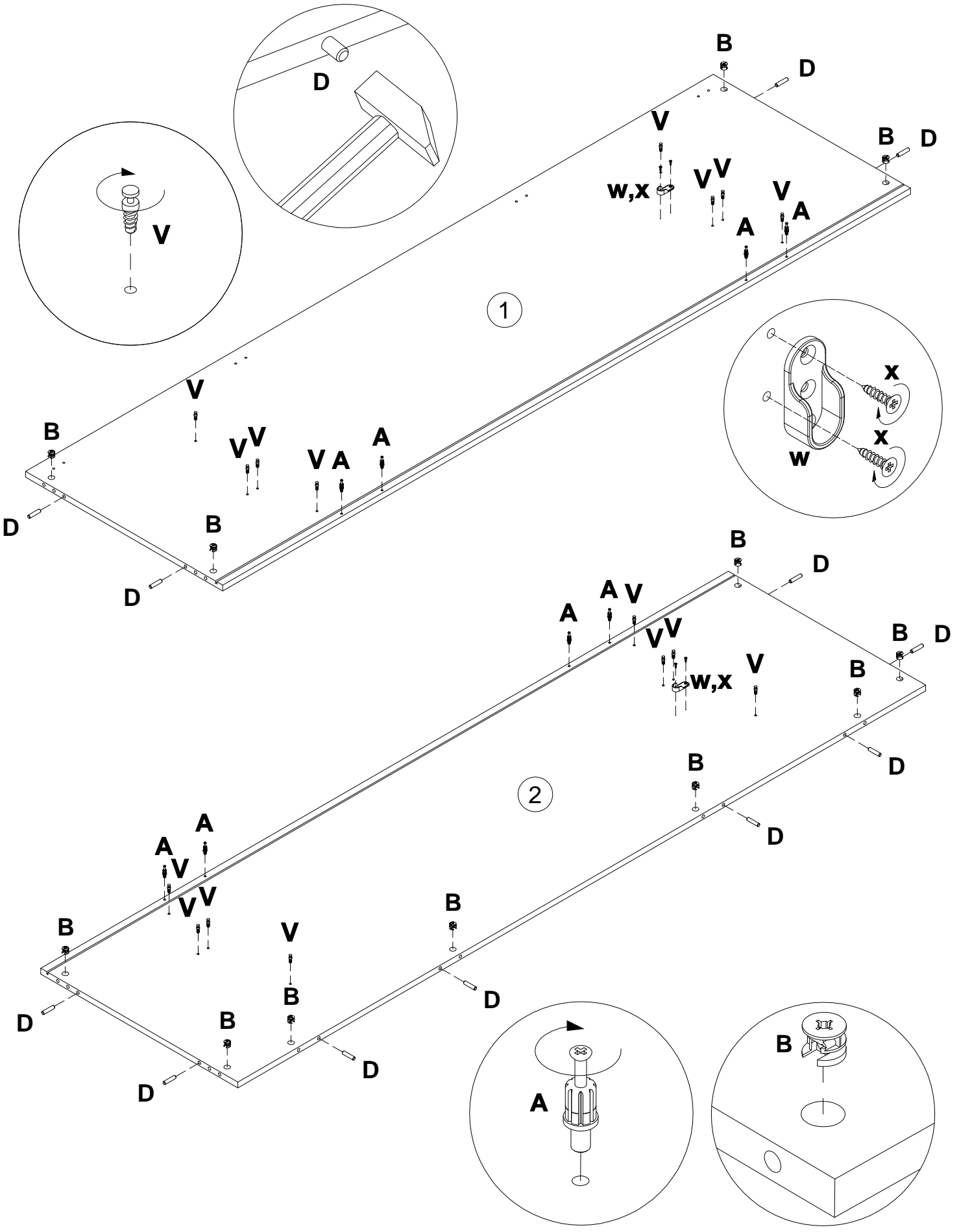

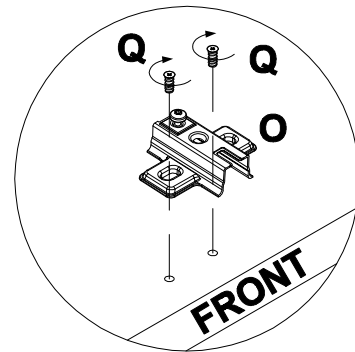
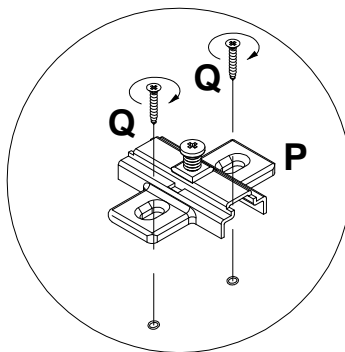
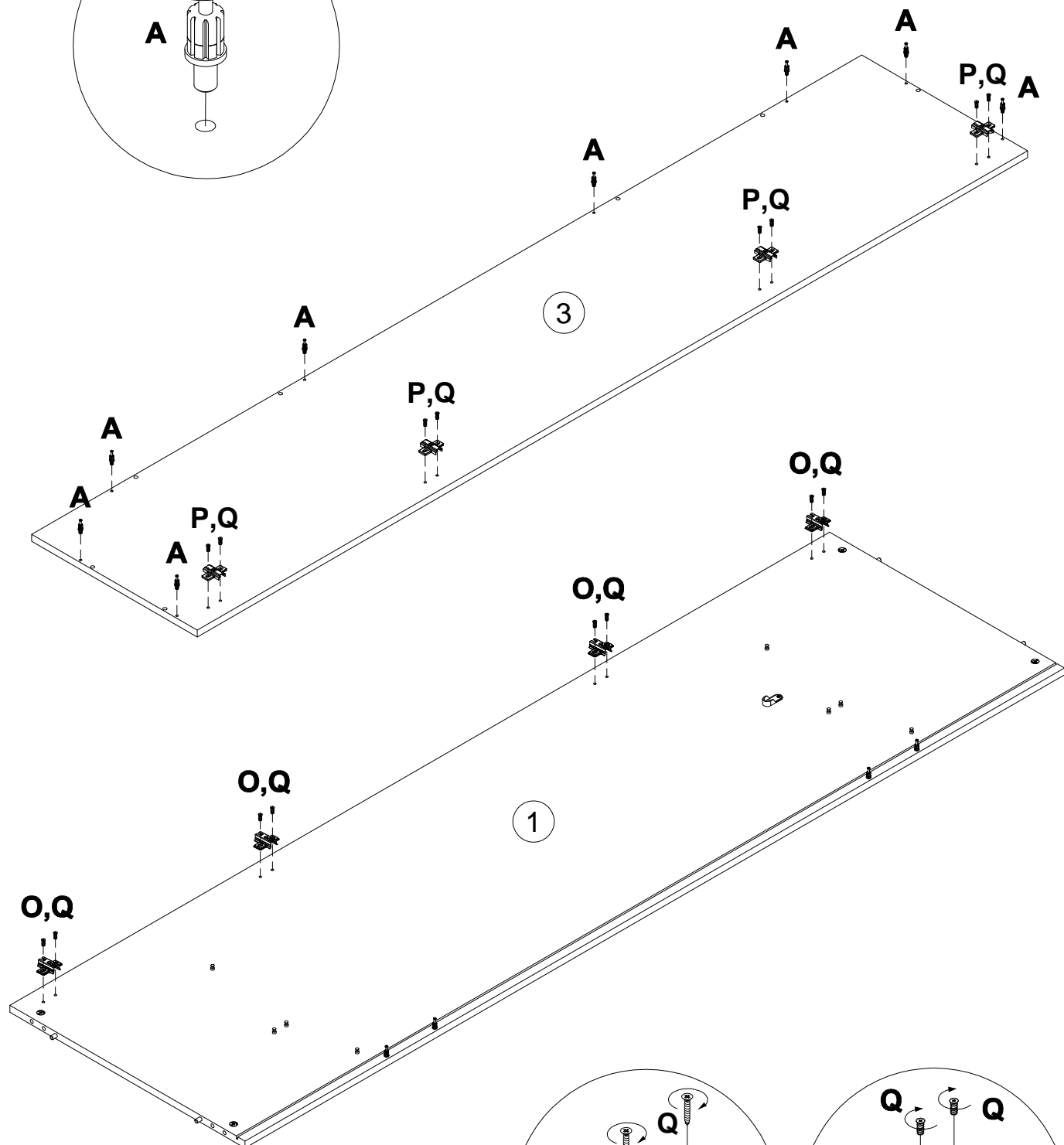
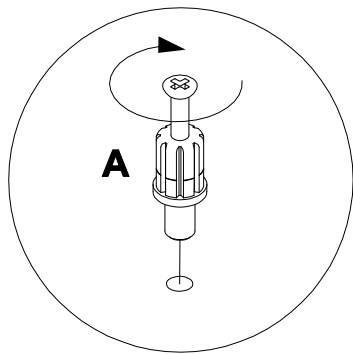
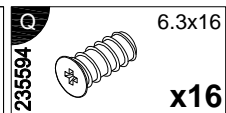
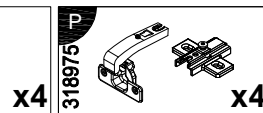
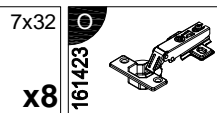
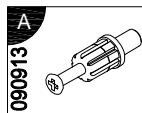

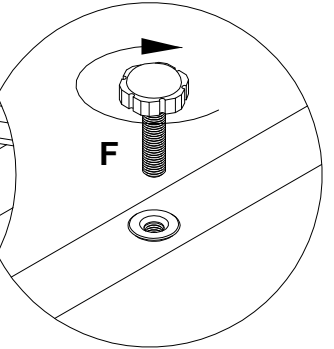
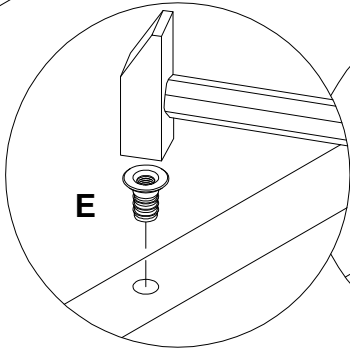
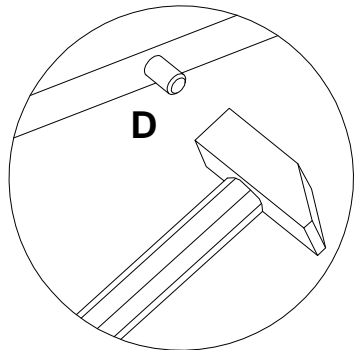
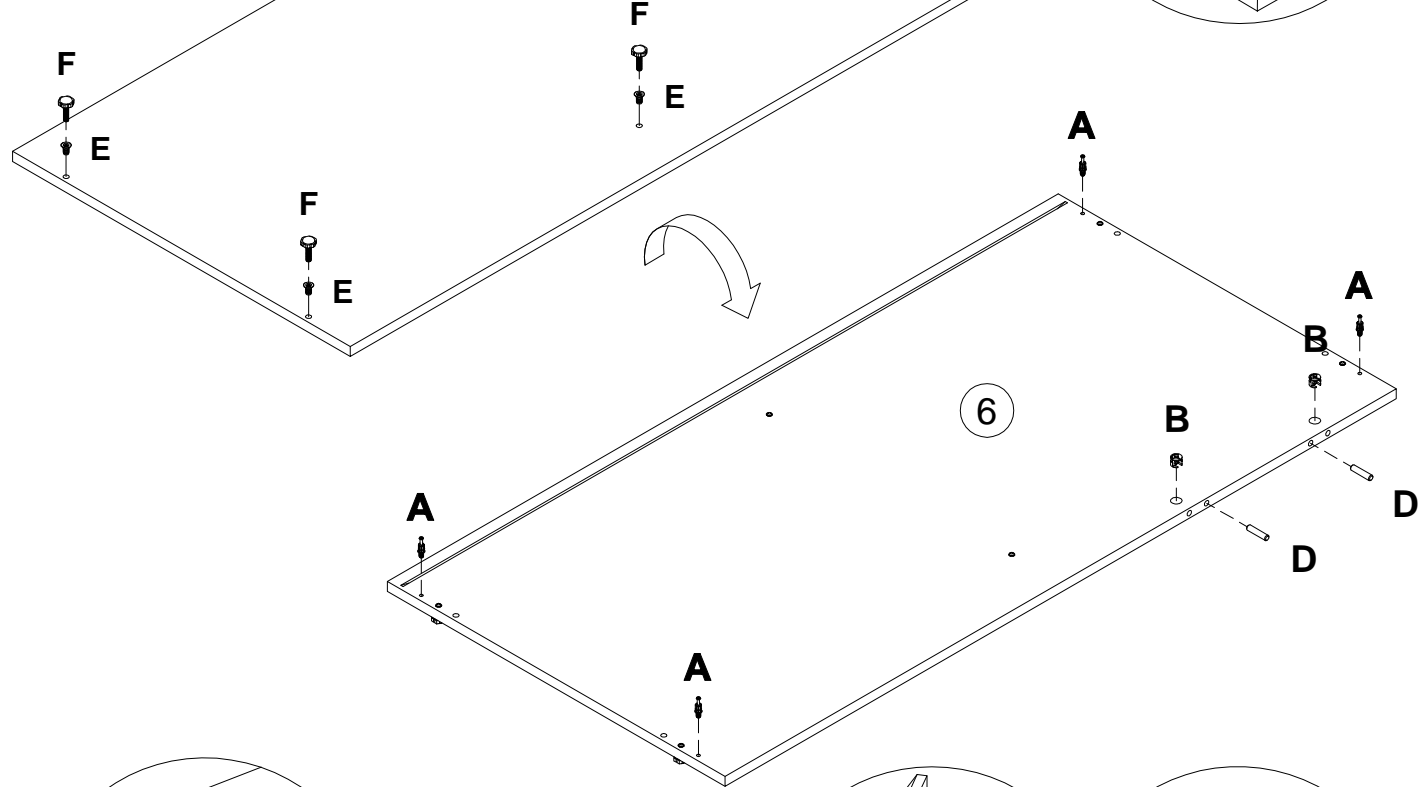
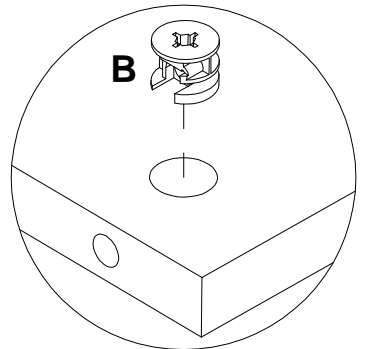
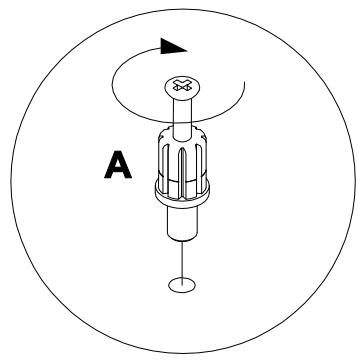
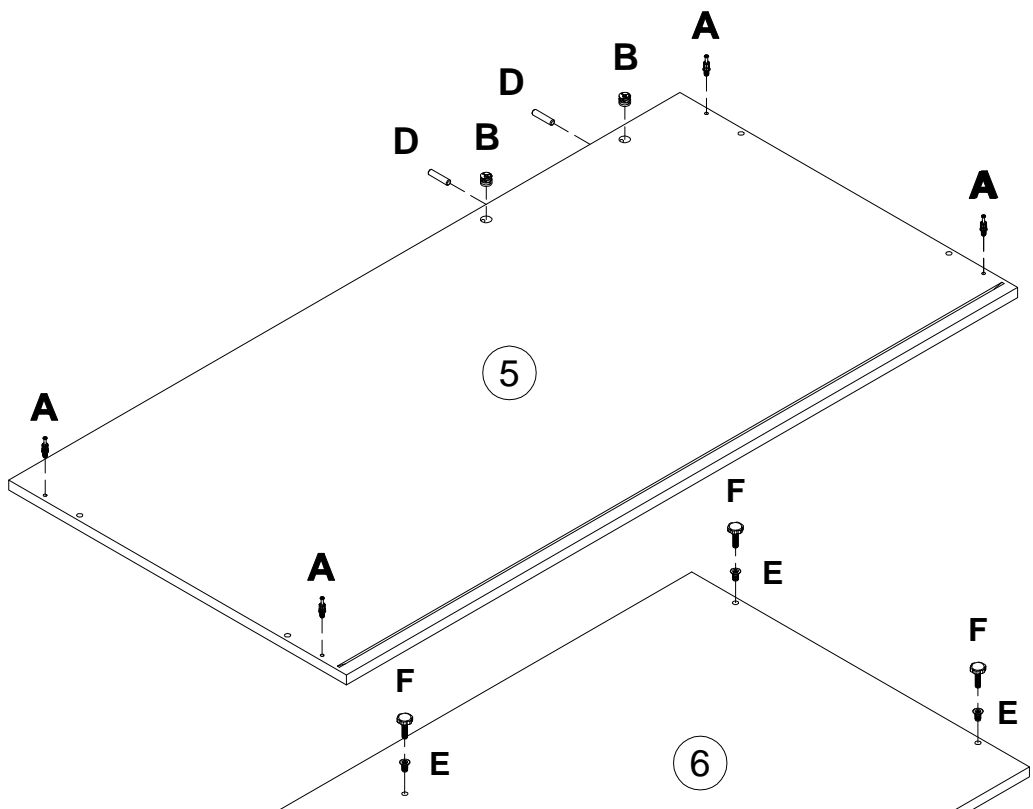

A 090913 7x32 x8	B 000146 15x12 x4	D 000151 8x35 x4	E 007086 M6 x6	F 208693 M6x16 x6
----------------------------------	-----------------------------------	----------------------------------	--------------------------------	-----------------------------------



8

000146		15x12	
		x8	x16

x2

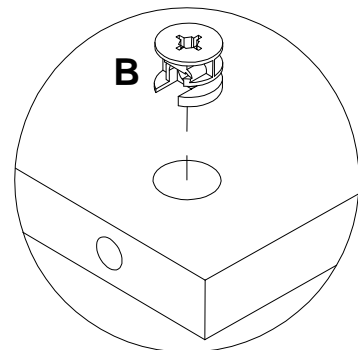
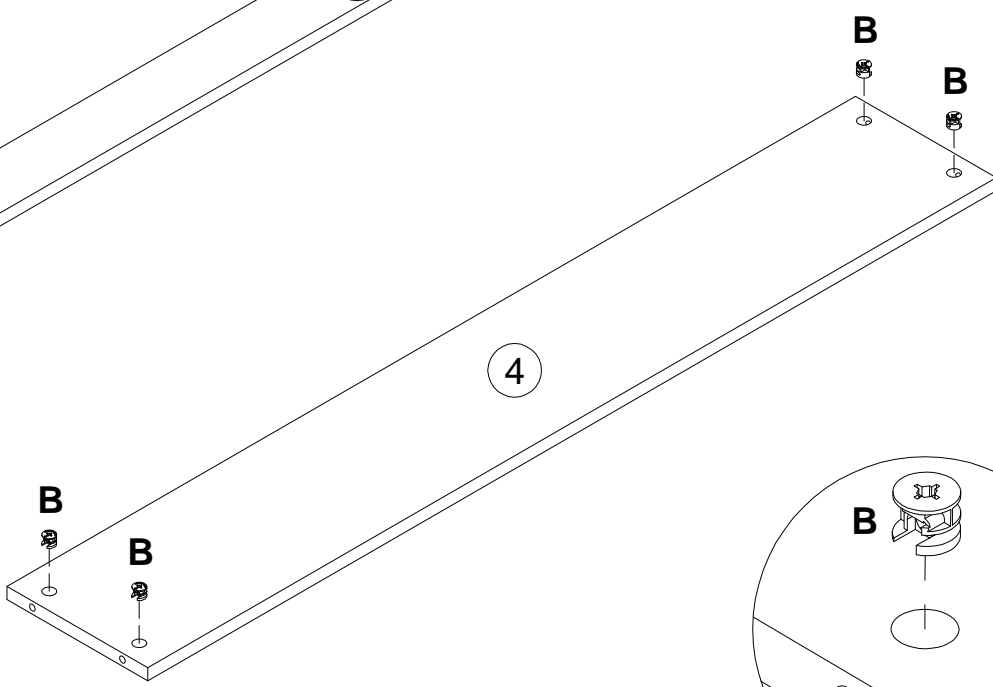
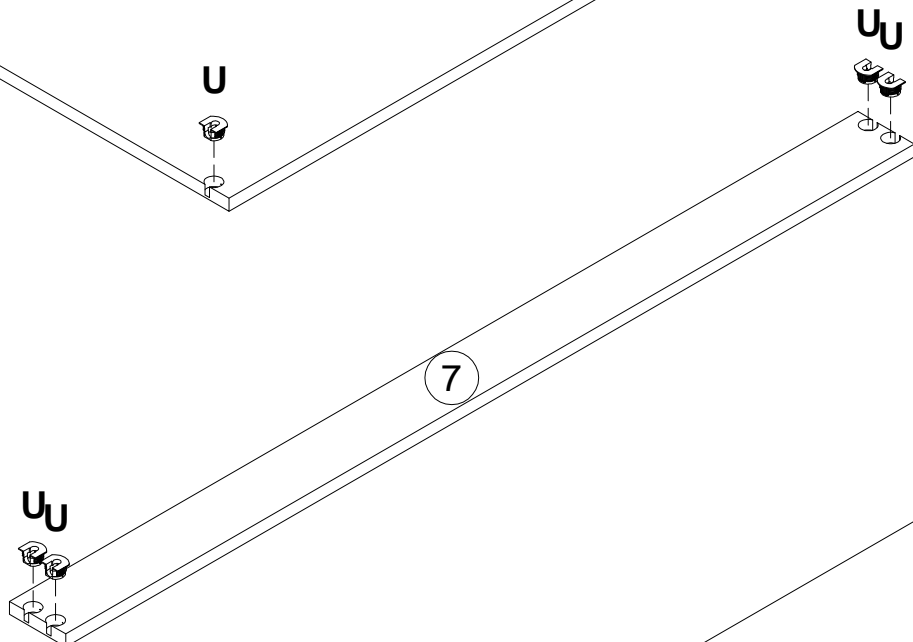
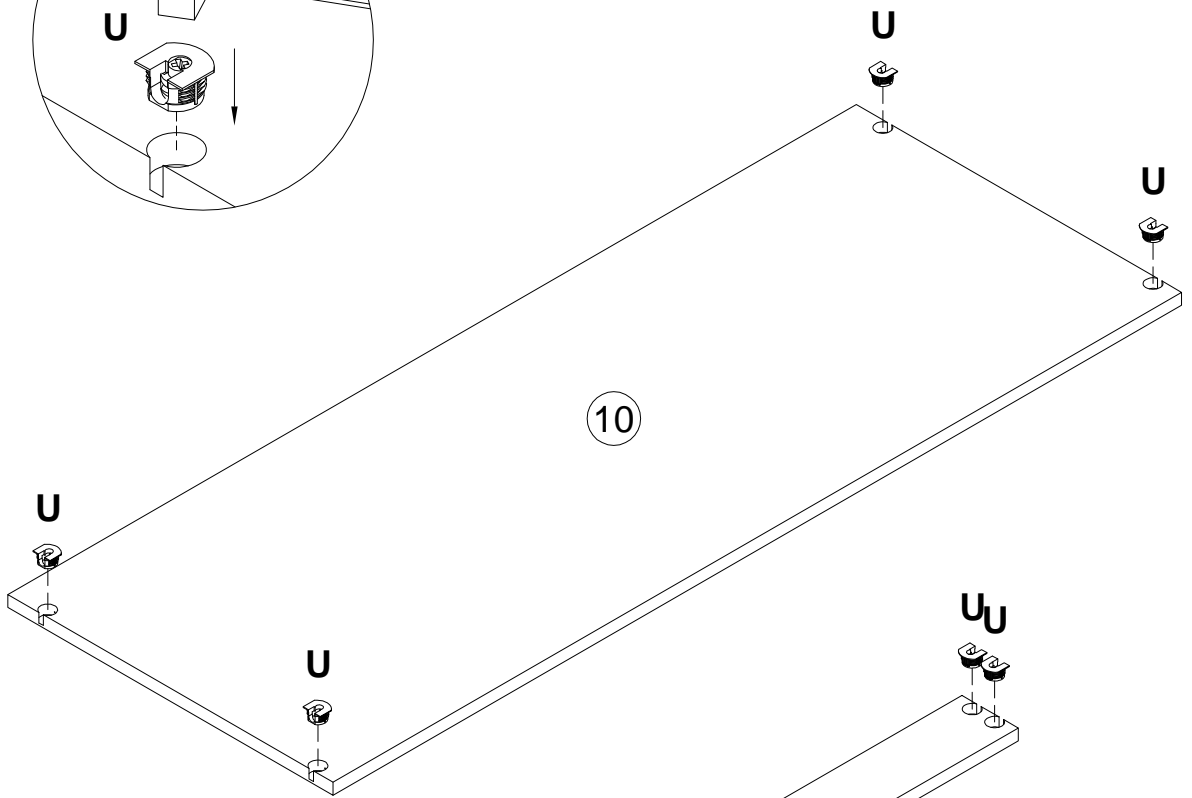
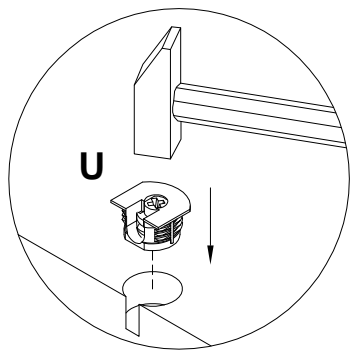

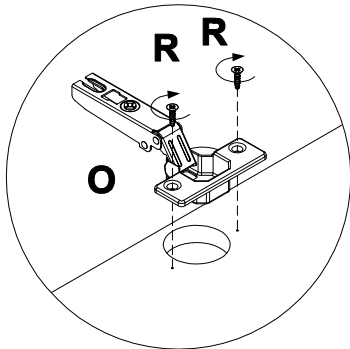
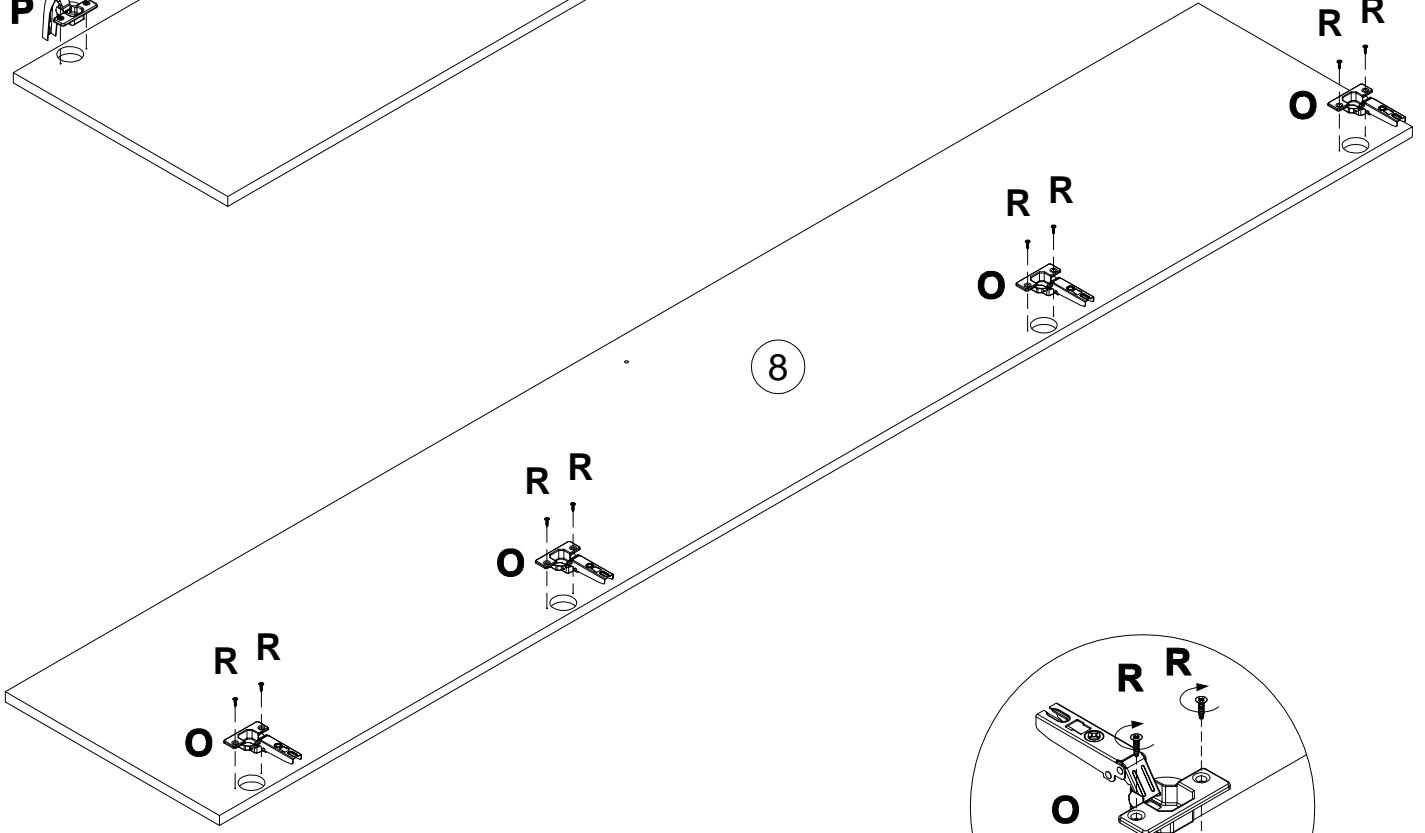
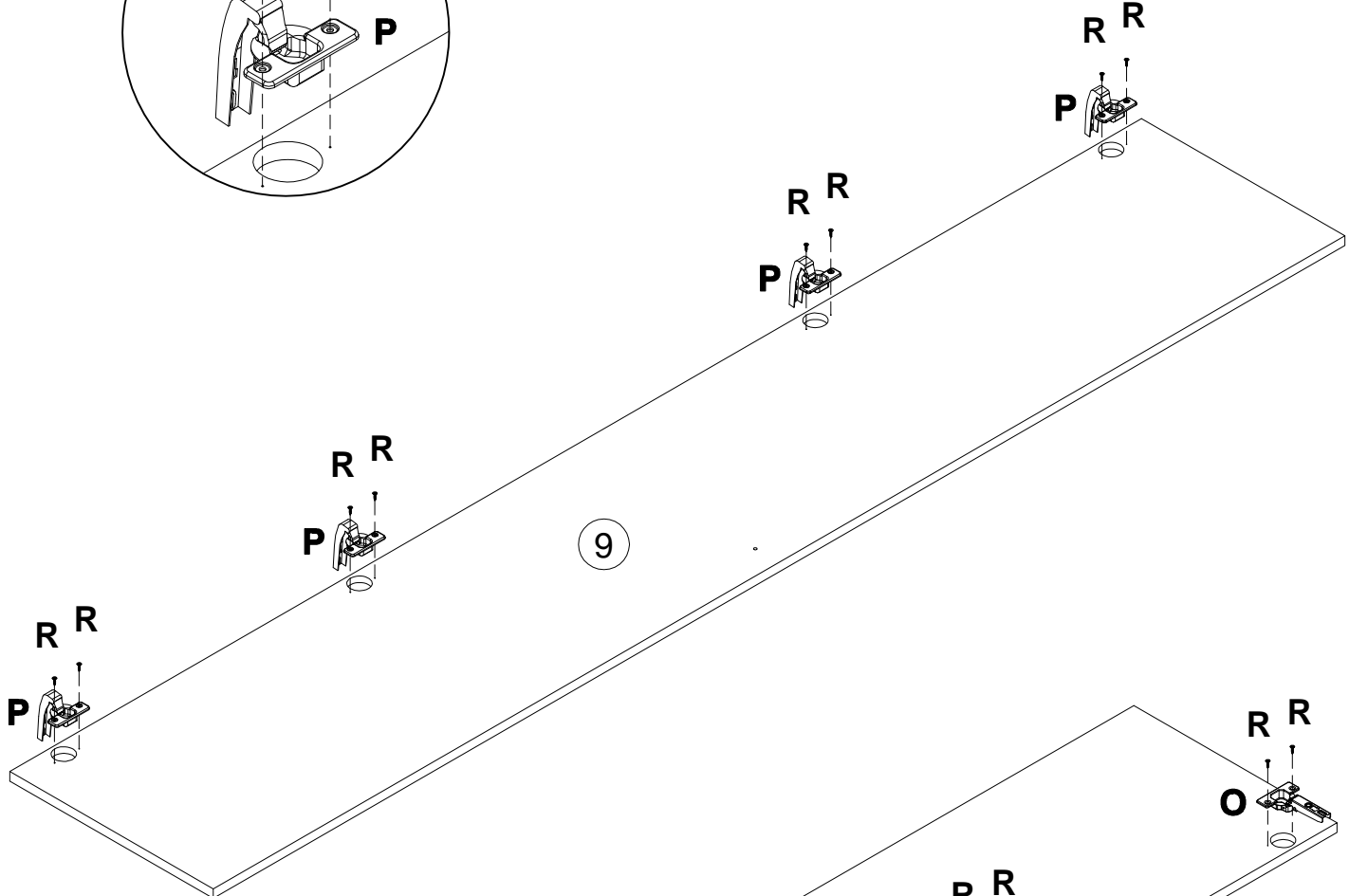
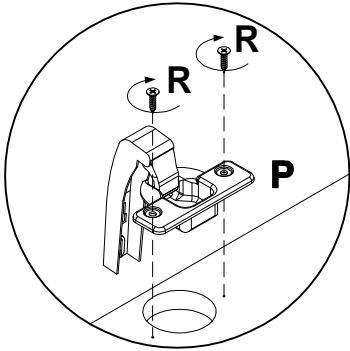
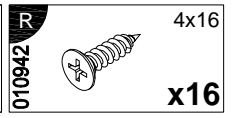
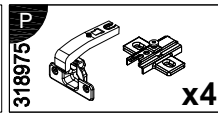
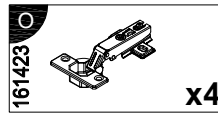

10

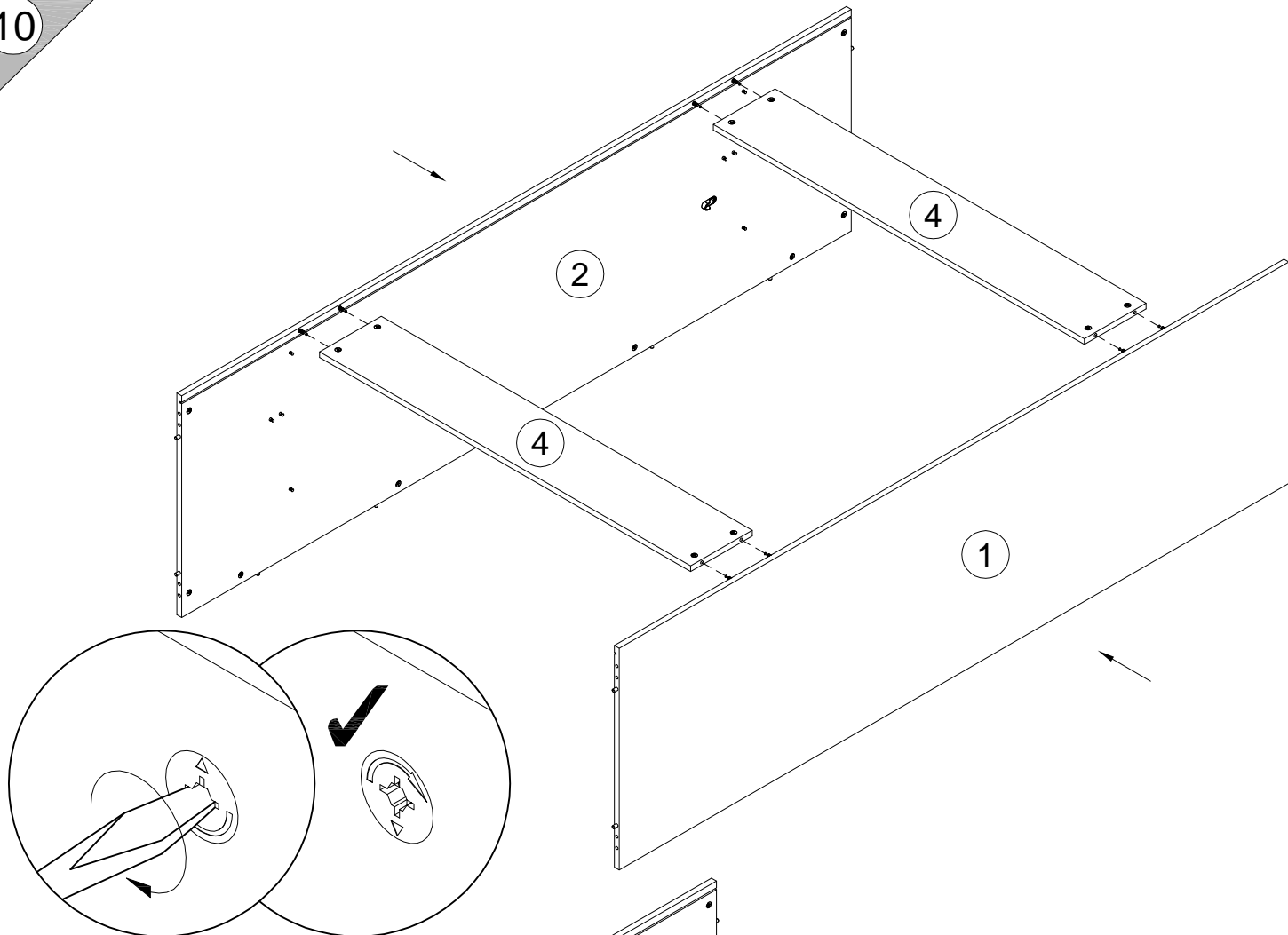

11

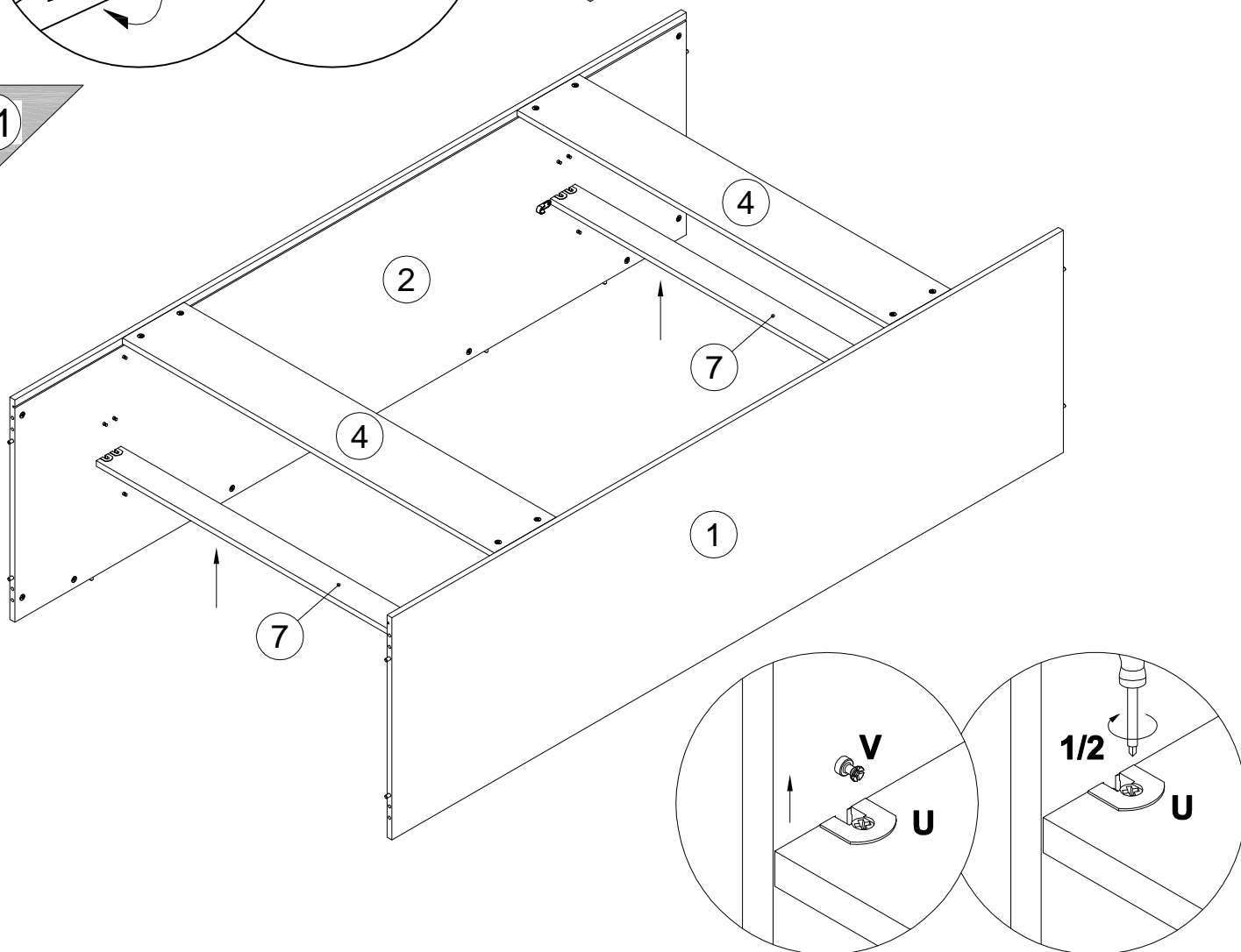

12

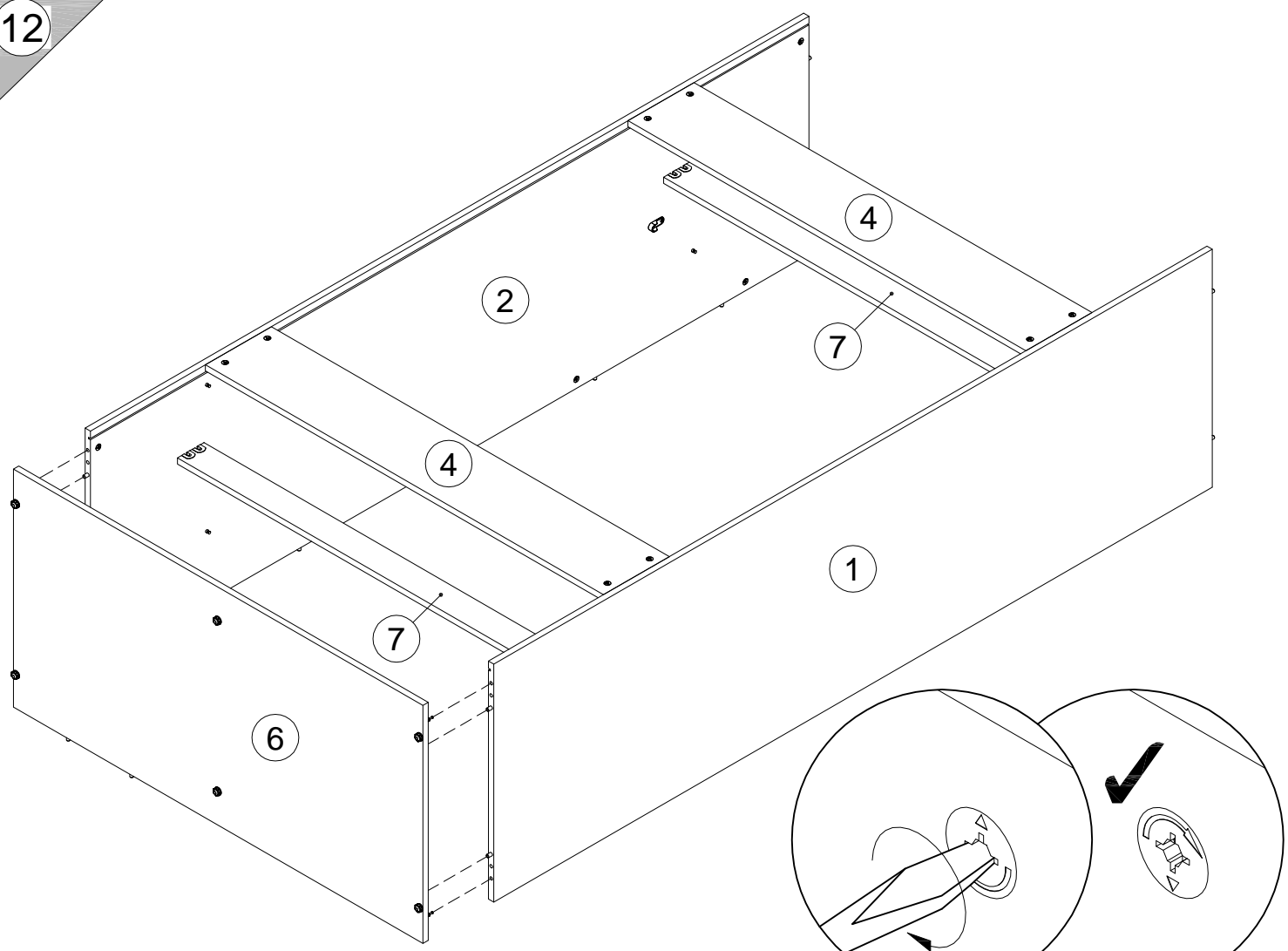

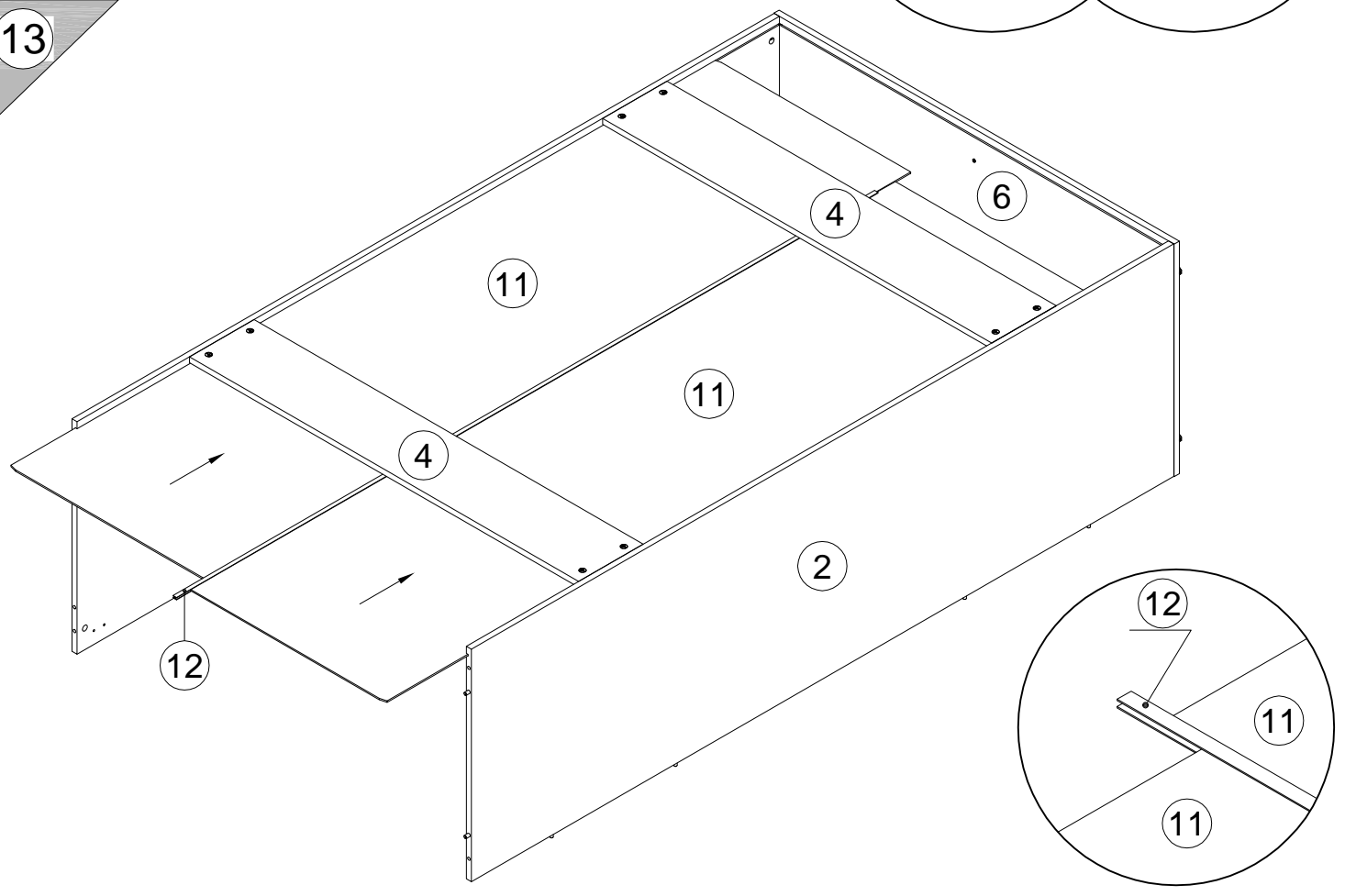

13

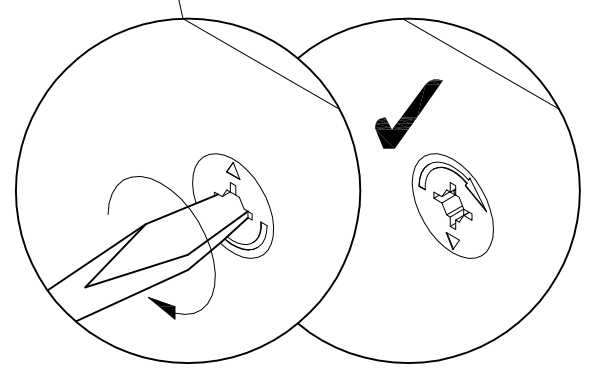
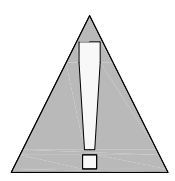
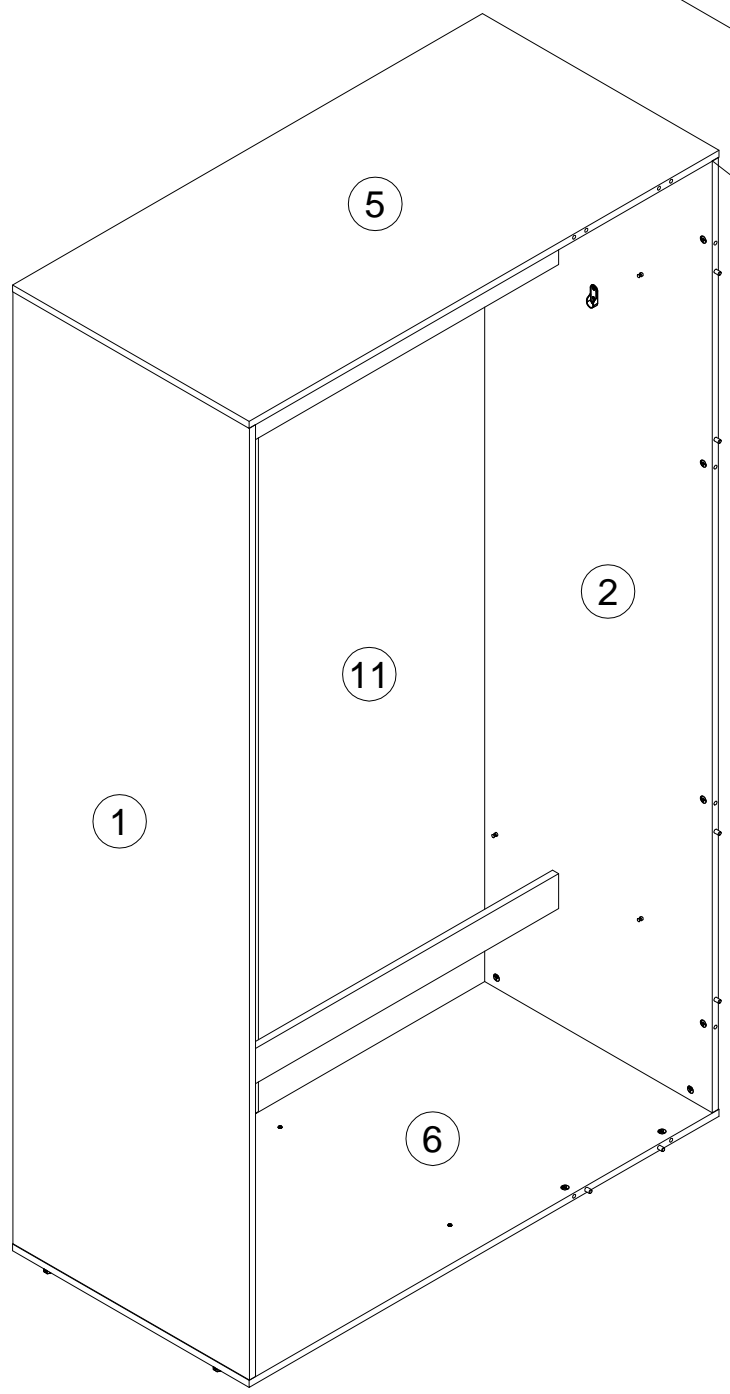
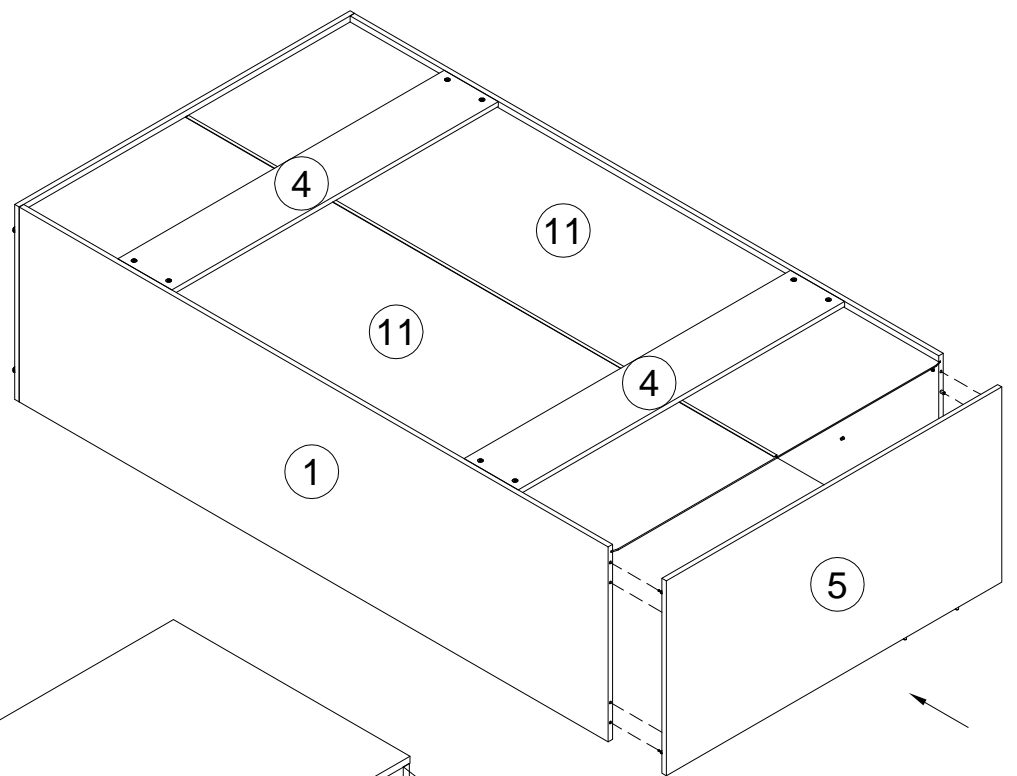

11



C 100640		20x0.5	M 135021		x20	N 000759		3x20	x20
--------------------	--	--------	--------------------	--	-----	--------------------	--	------	-----

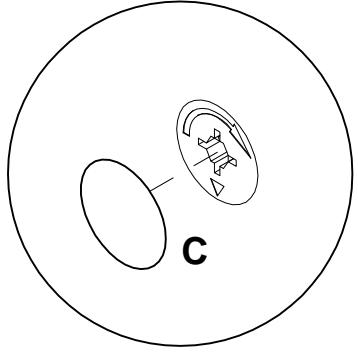
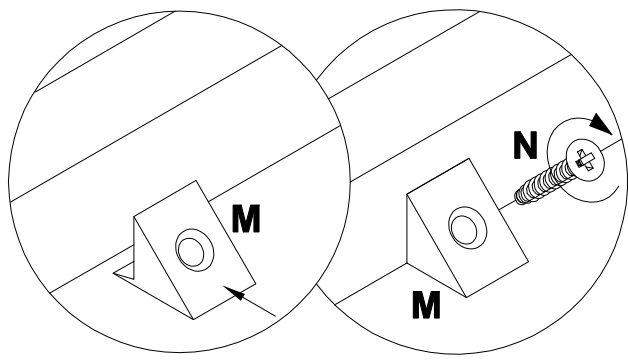
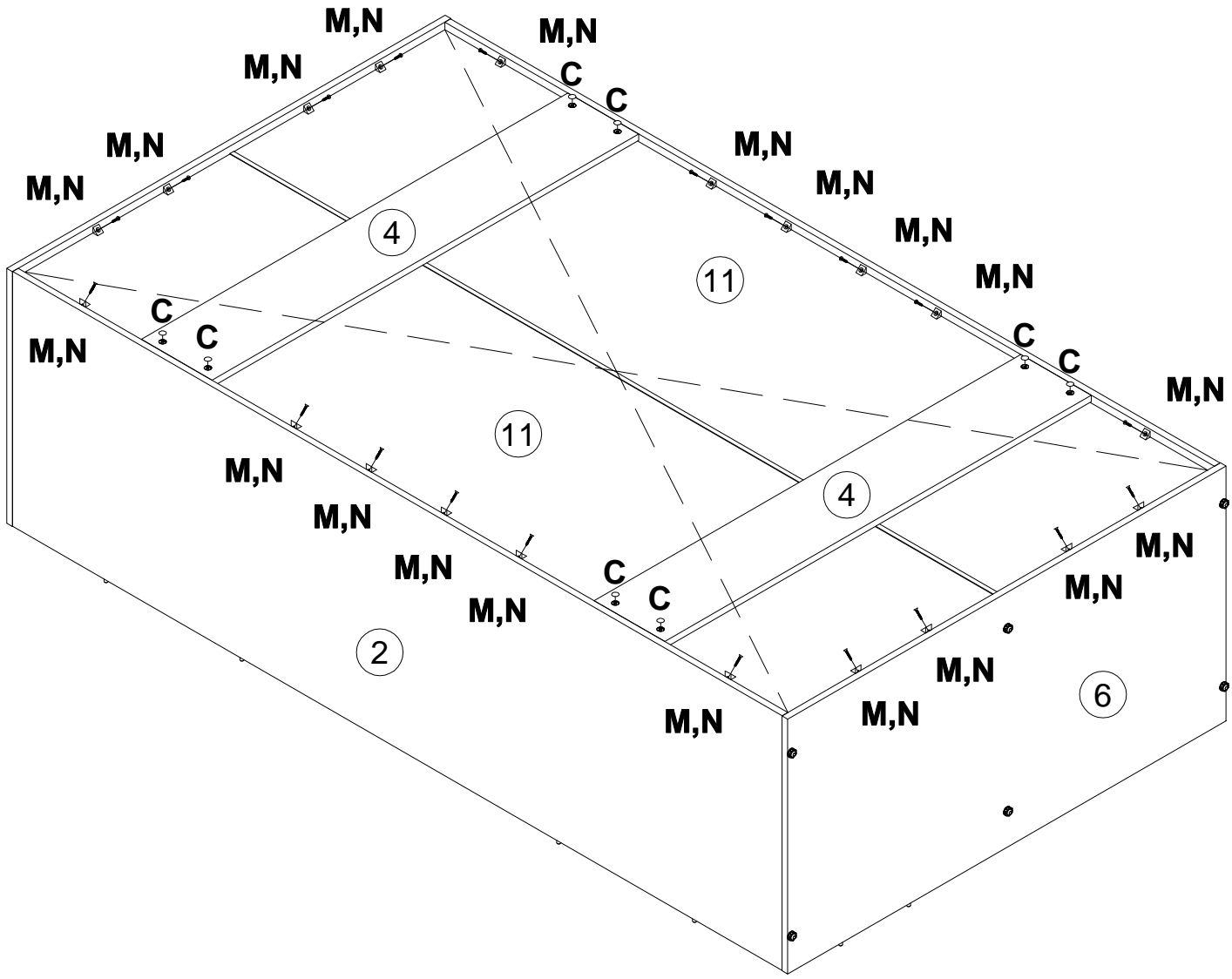

- C** 100640 20x0.5 x8
- G** 155999 x1
- H** 000754 3.5x16 x2
- I** 090185 4.5x45 x1
- J** 013859 8x40 x1

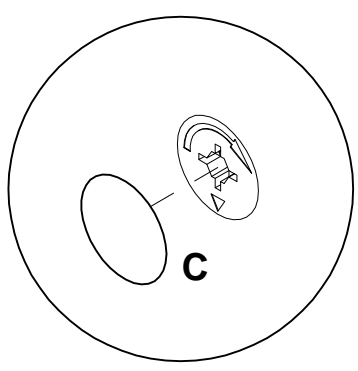
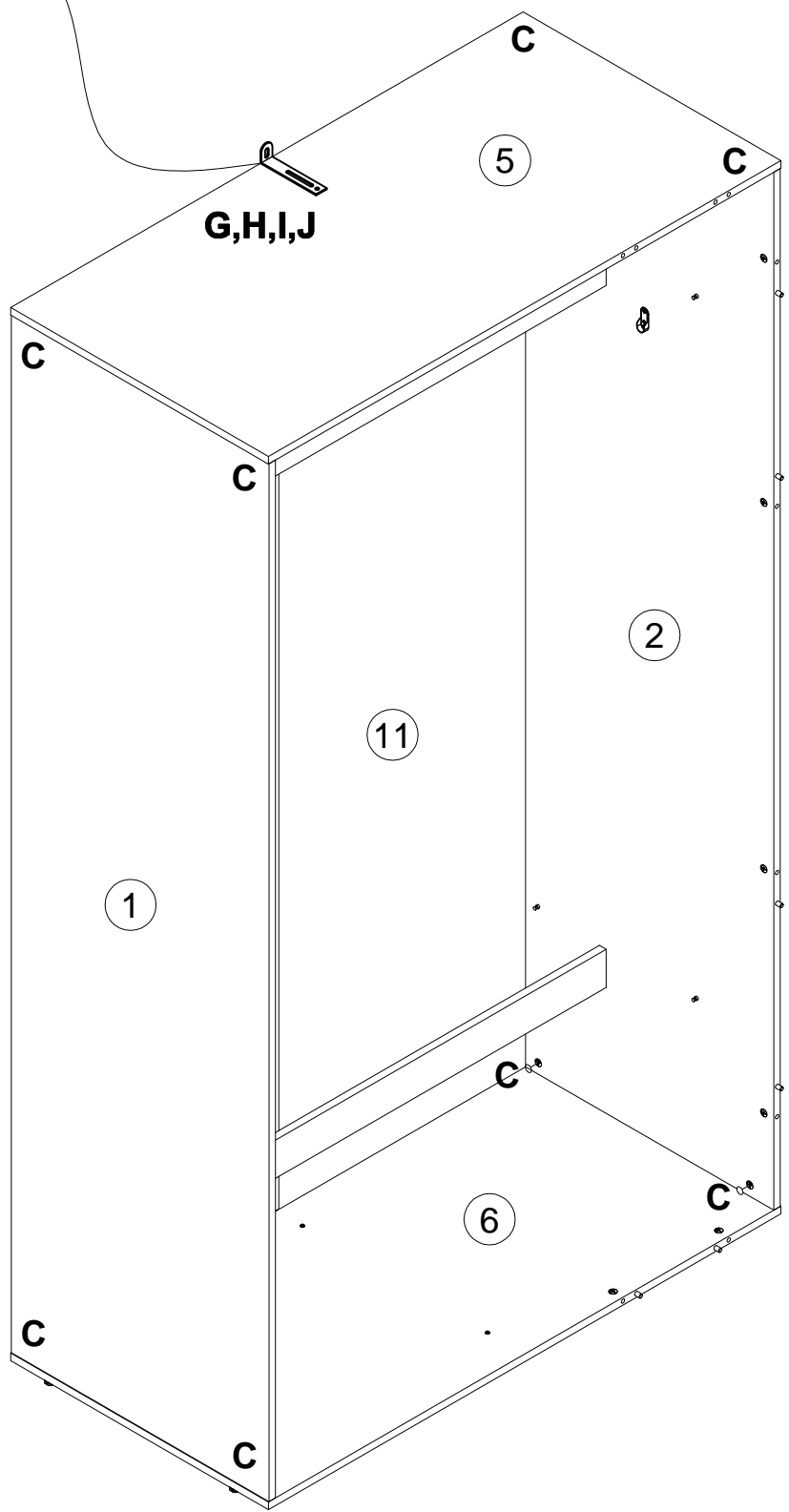
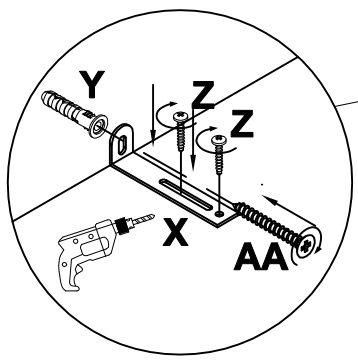

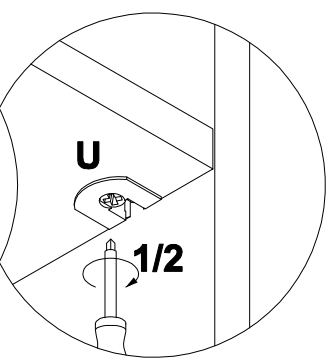
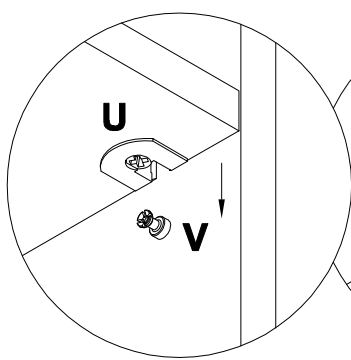
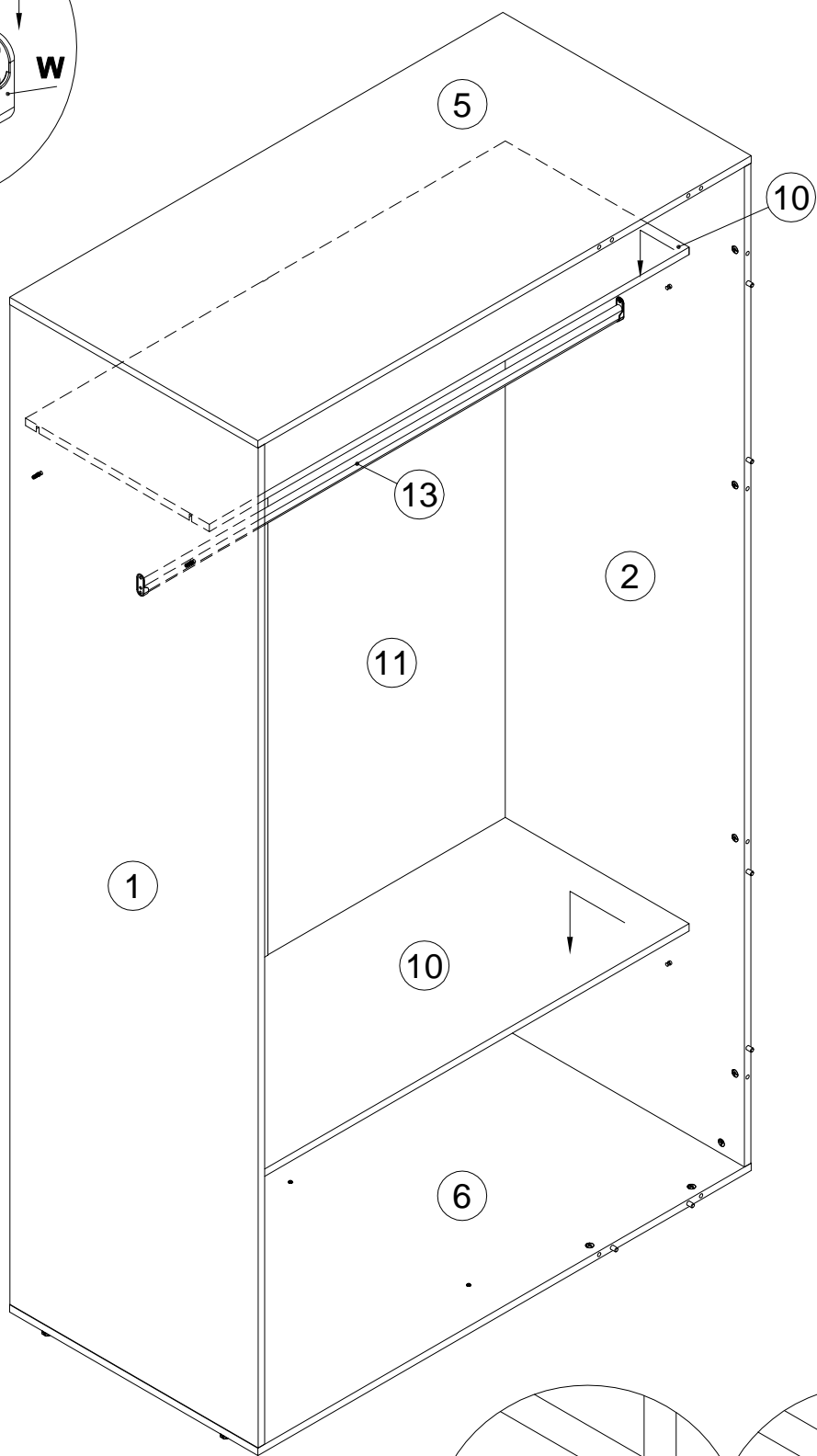
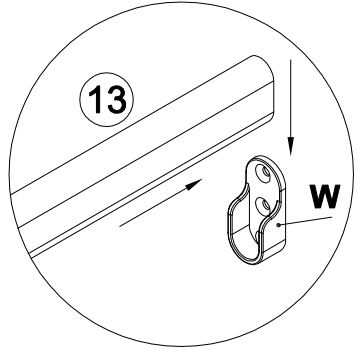

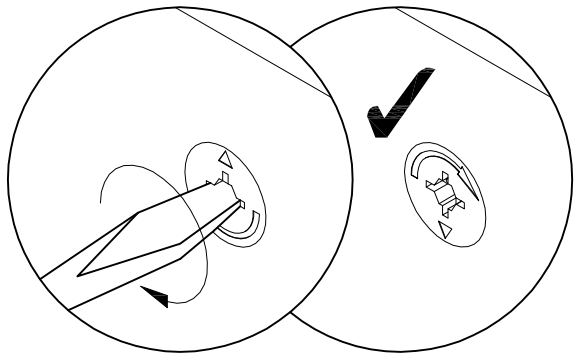
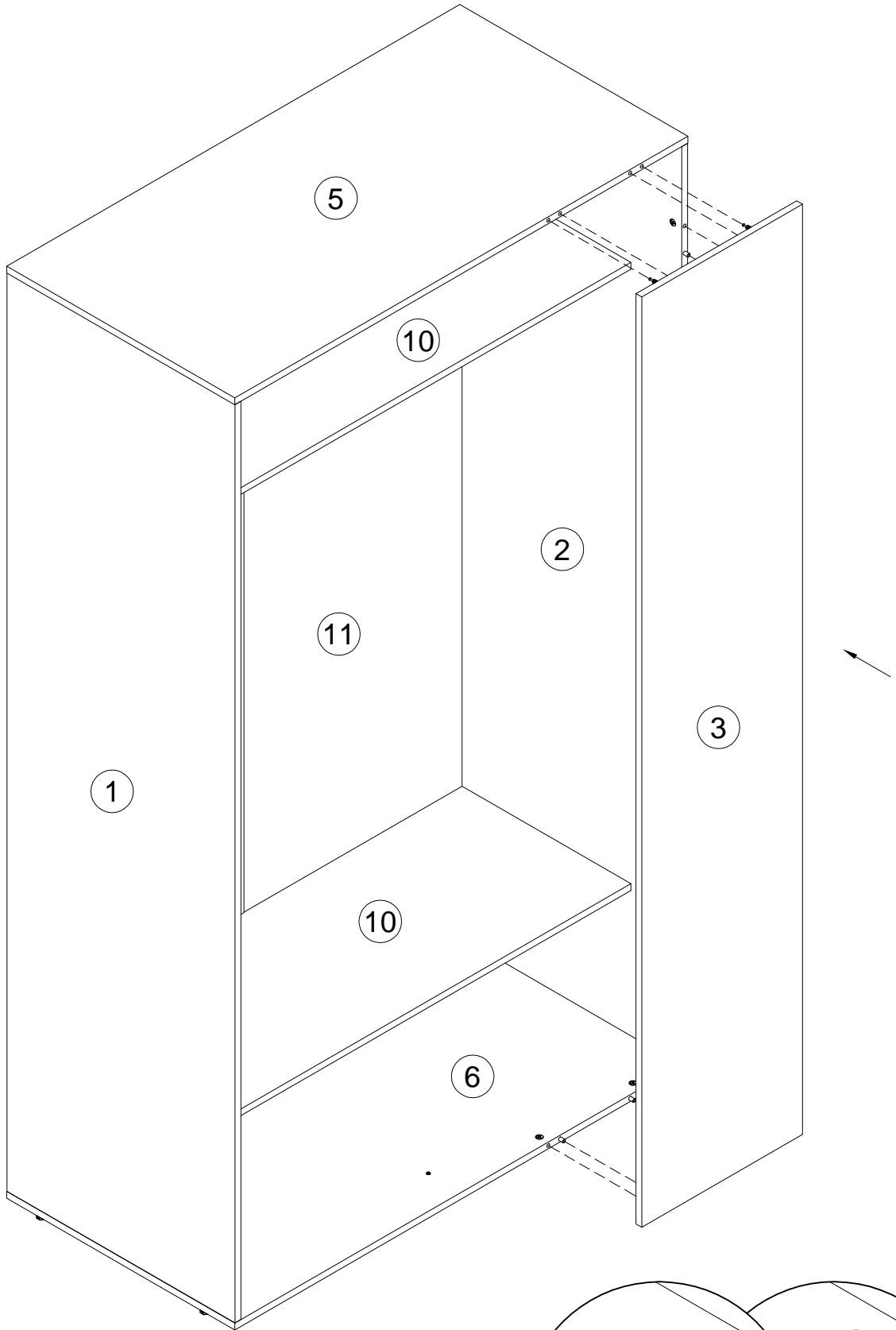

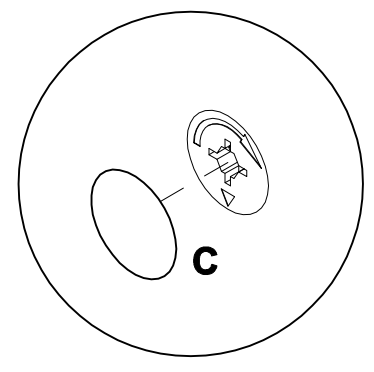
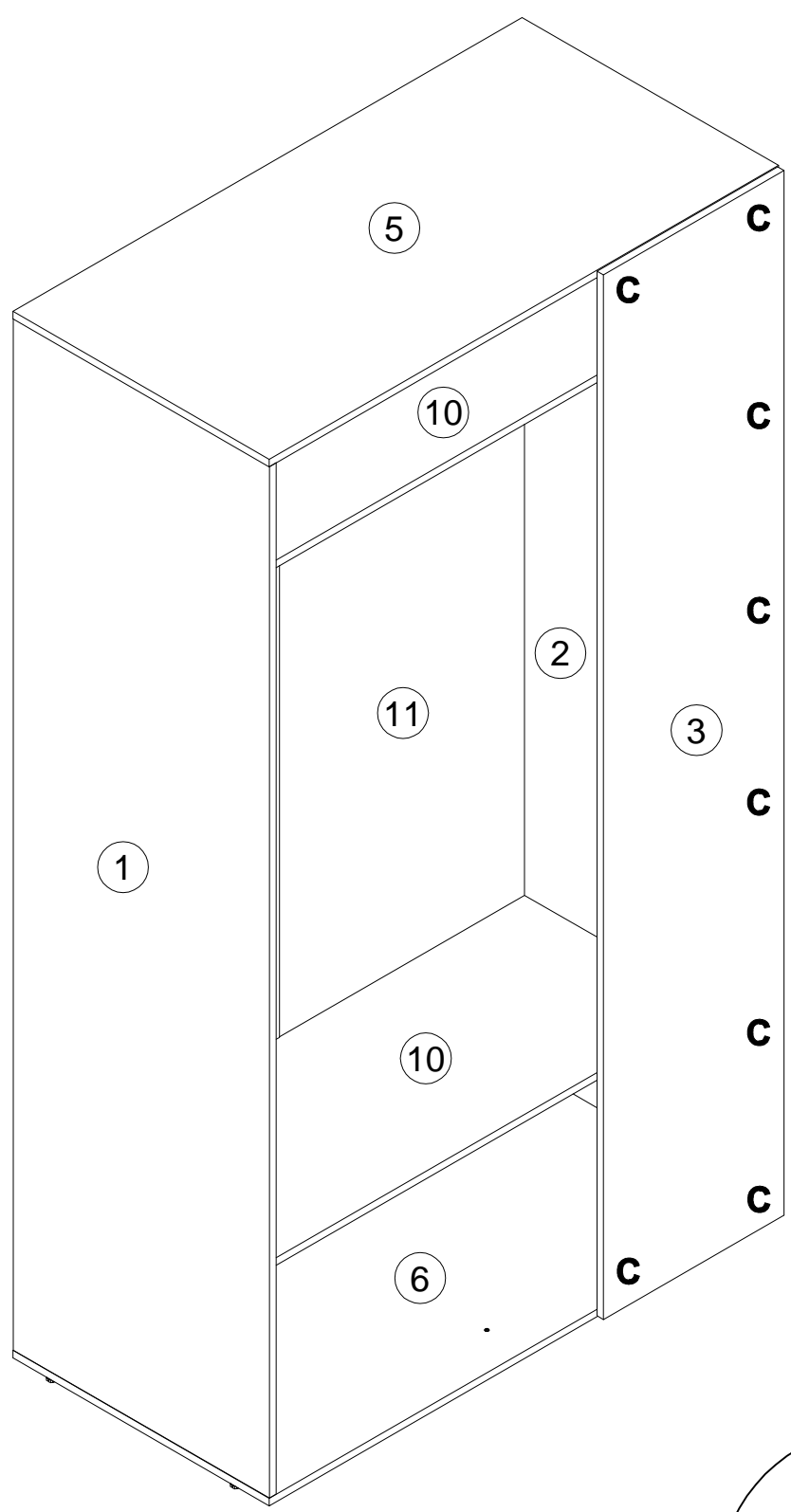

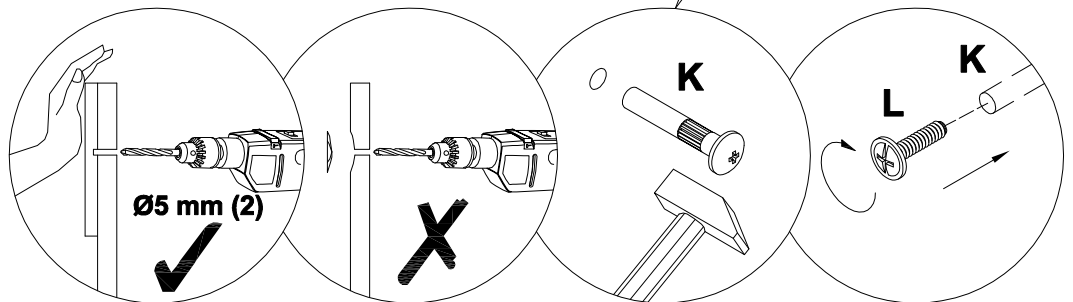
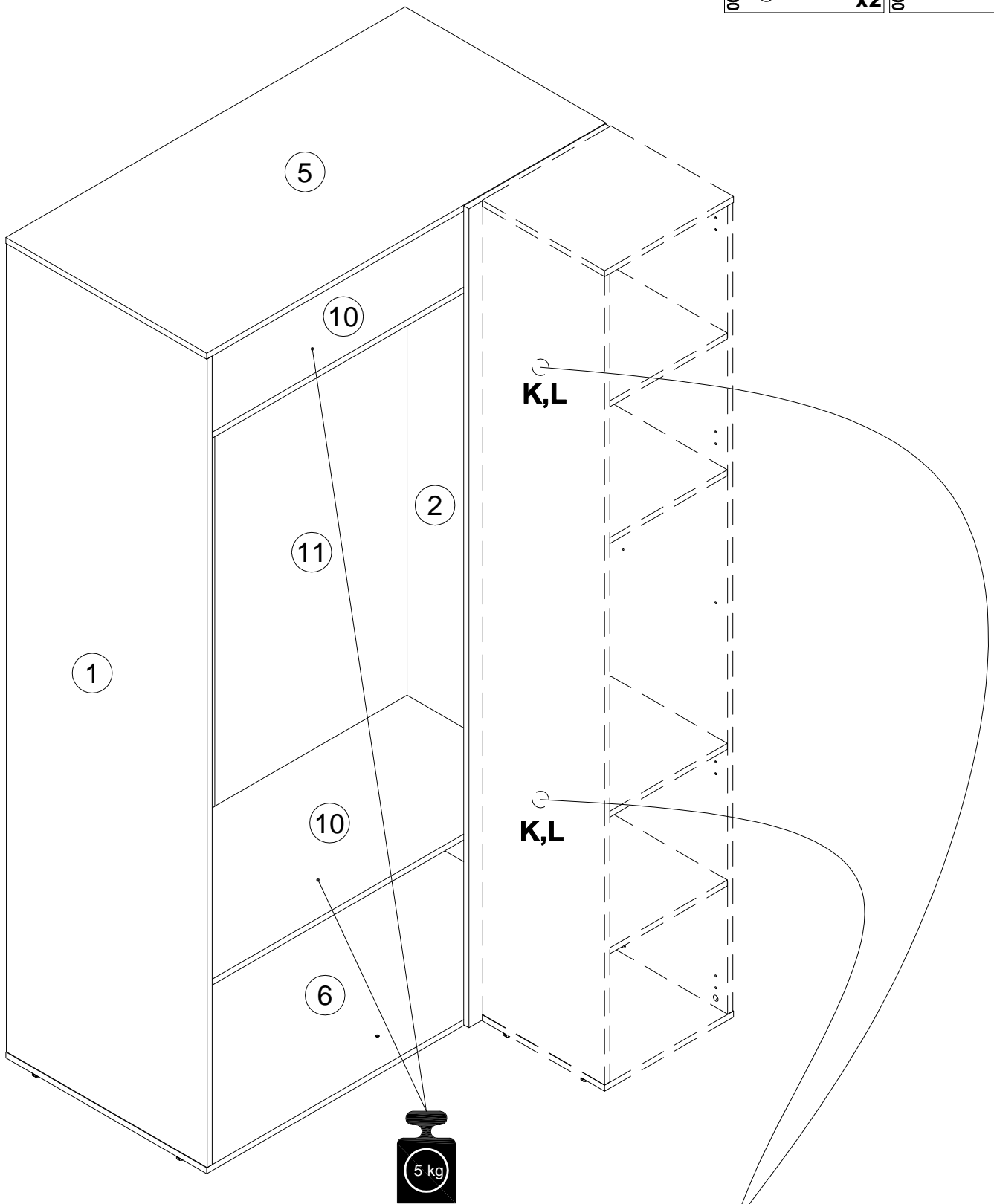
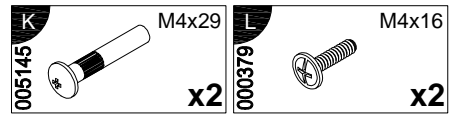



S 310591		x2	T 002704		M4x20	x2
--------------------	---	-----------	--------------------	---	-------	-----------

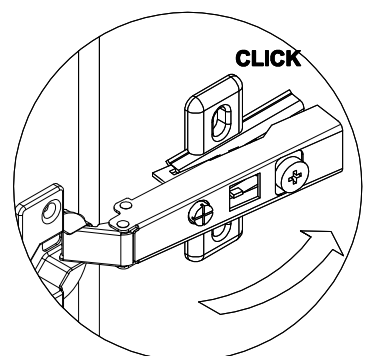
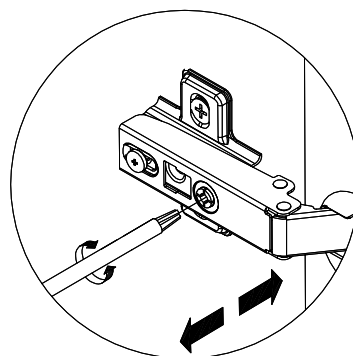
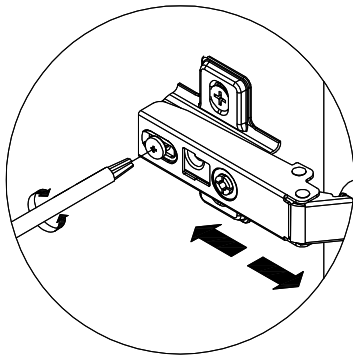
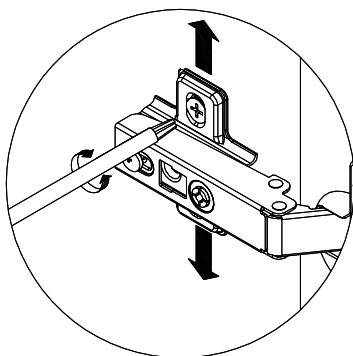
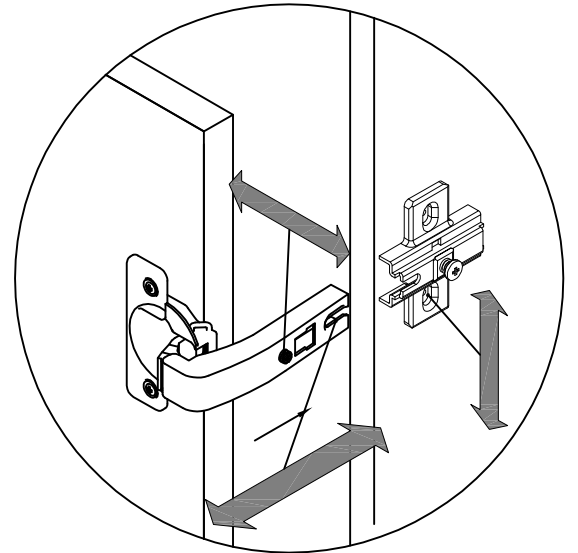
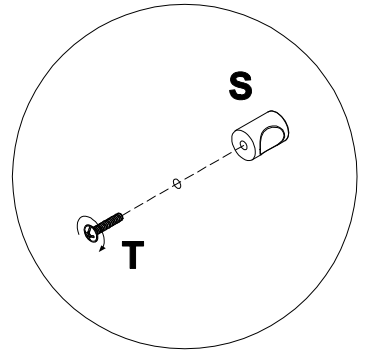
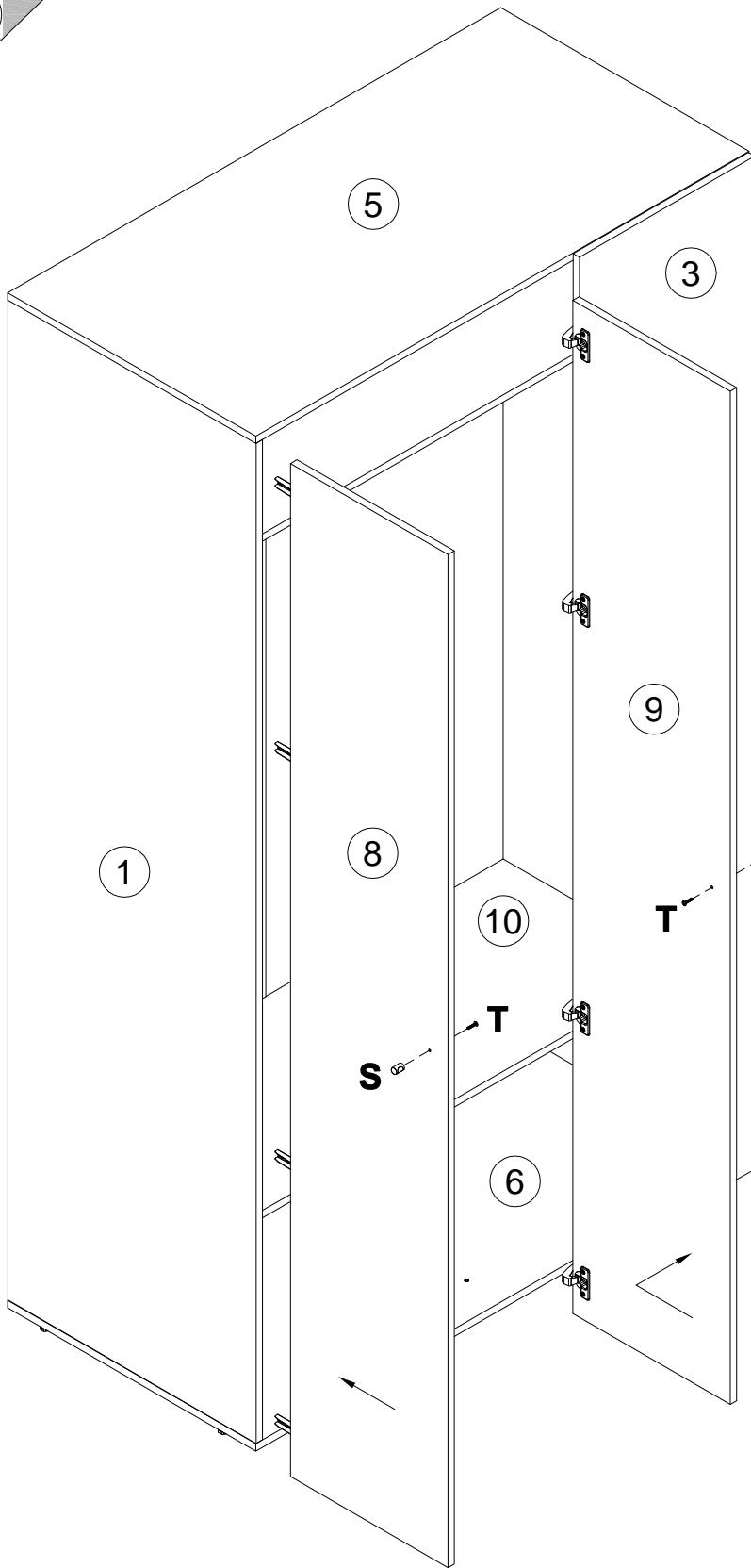

Инструкция по уходу за мебелью и правила эксплуатации

1. Мебель рекомендуется эксплуатировать в бытовых помещениях с температурой воздуха не ниже +2°С и относительной влажностью 45-70%.
2. Мебель должна быть защищена от воздействия прямых солнечных лучей, так как это вредит внешнему виду изделий и может изменить цвет поверхности.
3. Не следует ставить на поверхность мебели горячие предметы.
4. Случайно попавшую на поверхность изделия влагу, жидкость следует снять сухой тканью.
5. Удаление пыли с полированной или лакированной поверхности следует производить сухой тканью (фланель, миткаль).
6. Полированные и лакированные поверхности мебели рекомендуется освежать специально предназначенными для этого средствами.
7. Очищать стекла рекомендуется специальными составами, нанесенными на мягкую ткань.
8. Не допускается применение соды, стиральных порошков, абразивных паст, порошков и прочих, не предназначенных для ухода за изделиями мебели препаратов.

В связи с постоянной работой, направленной на улучшение потребительских свойств мебели, предприятие-изготовитель оставляет за собой право на изменения конструкции, не влияющие на качество и внешний вид изделия.