

EAC

инструкция по сборке
Шкаф арт. 5086

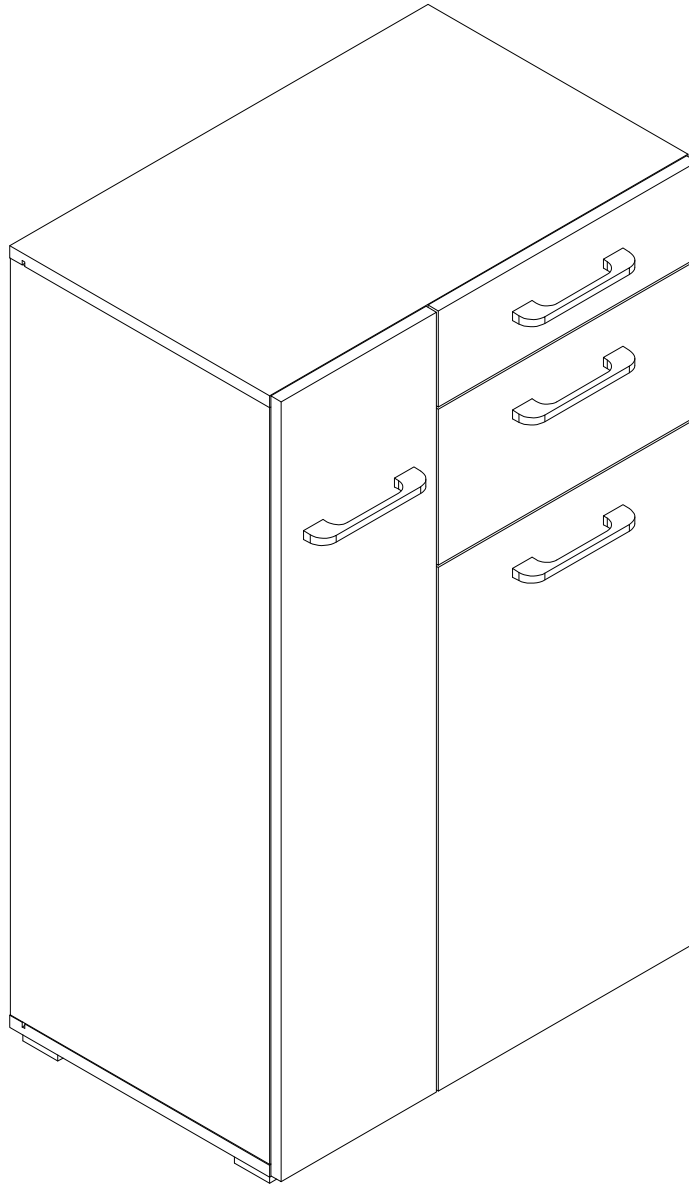

габаритные размеры

высота - 1062 мм

ширина - 644 мм

глубина - 416 мм

единая справочная служба:

8 800 100-50-22

(звонок по России бесплатный)

LAZURIT
FURNITURE FACTORY

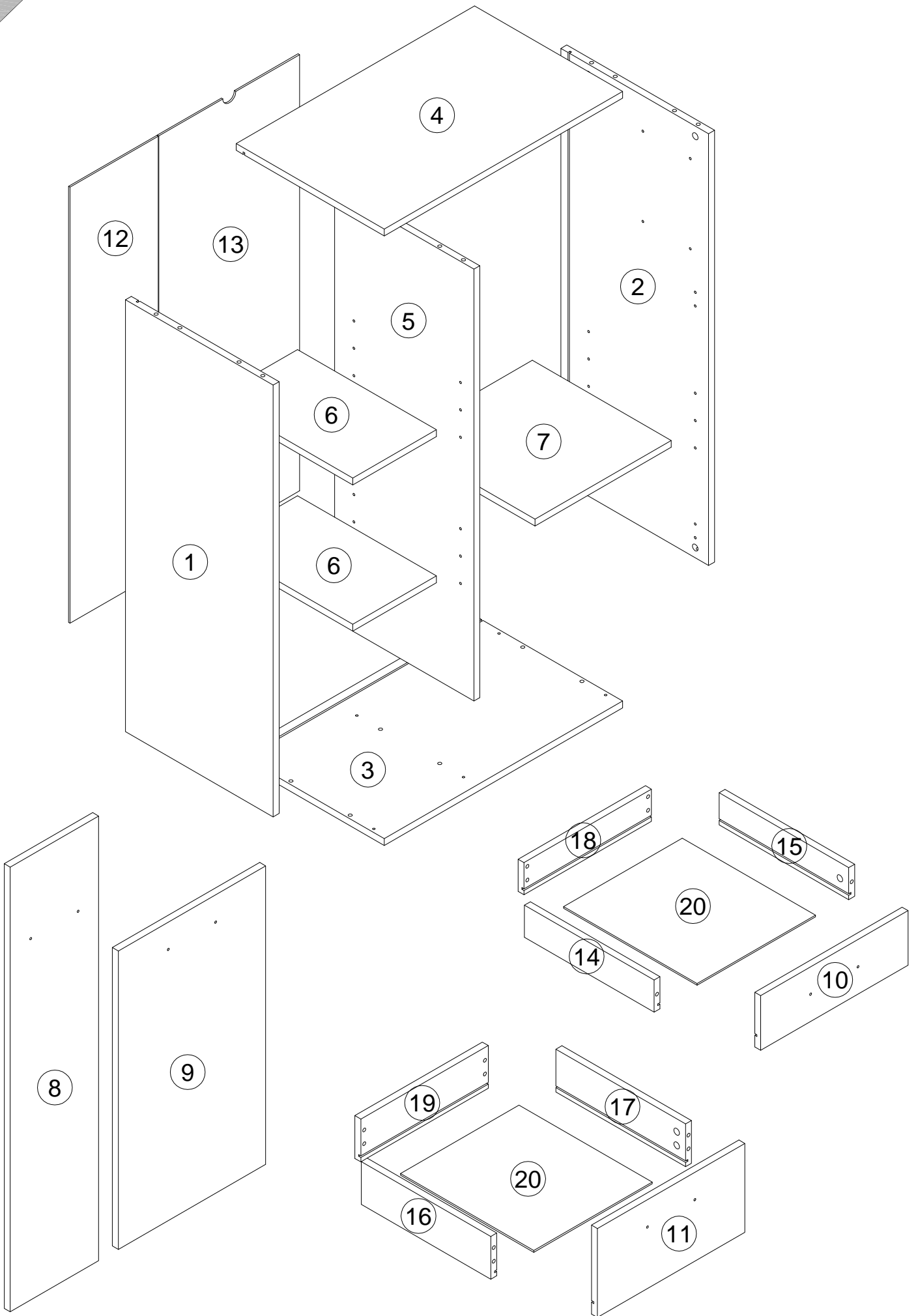





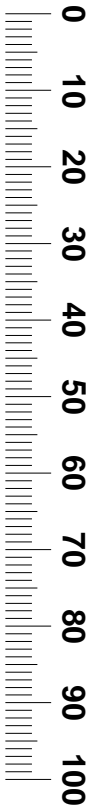
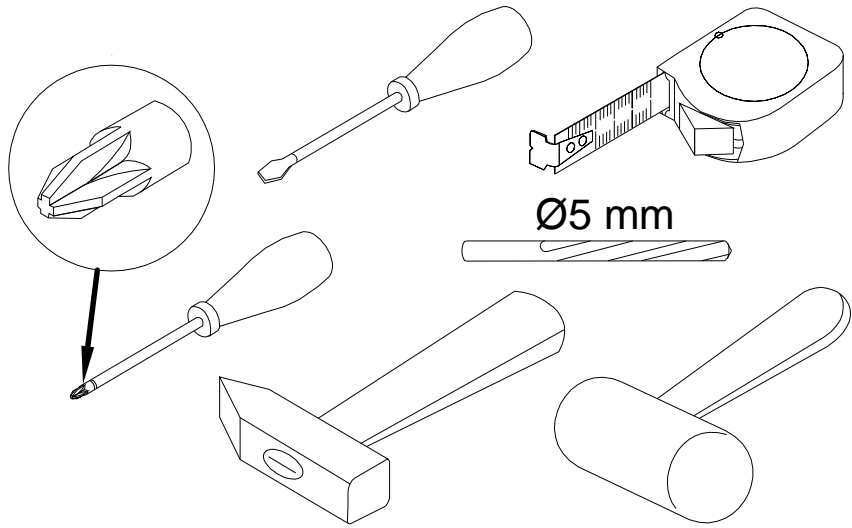
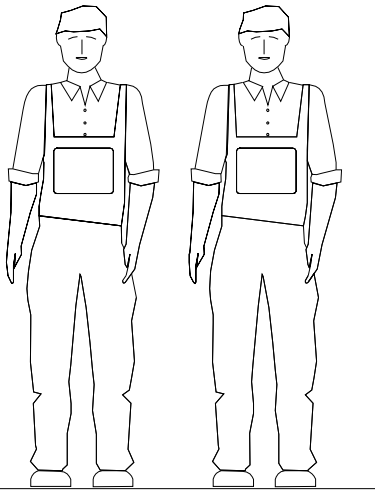



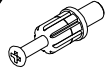



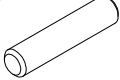



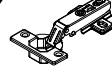





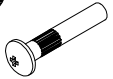

поз.	наименование детали	№ упак.	шт.	длина, мм	ширина, мм
1	Стенка боковая	2	1	1010	399
2	Стенка боковая	2	1	1010	399
3	Стенка горизонтальная	1	1	644	400
4	Стенка горизонтальная	1	1	644	400
5	Стенка-перегородка	2	1	1010	376
6	Полка	1	2	226	375
7	Полка	1	1	368	375
8	Дверь	2	1	1040	239
9	Дверь	1	1	698	398
10	Стенка передняя	1	1	398	128
11	Стенка передняя	1	1	398	208
12	Стенка задняя	2	1	1020	238
13	Стенка задняя	2	1	1020	380
14	Стенка боковая	1	1	350	75
15	Стенка боковая	1	1	350	75
16	Стенка боковая	1	1	350	100
17	Стенка боковая	1	1	350	100
18	Стенка боковая	1	1	344	75
19	Стенка боковая	1	1	344	100
20	Стенка горизонтальная	1	2	360	320

3

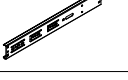

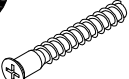
4

A 090913  7x32 x18	B 000146  15x12 x18	C 100640  20x0.5 x8	D 100640  20x0.5 x6	E 000151  8x35 x12	F 135021  x14
G 062367  x3	H 000759  3x20 x17	I 161423  x4	J 235594  6.3x16 x8	K 010942  4x16 x24	L 177473  x4
M 125913  x12	N 155999  x1	O 000754  3.5x16 x2	P 090185  4.5x45 x1	Q 013859  8x40 x1	R 005145  M4x29 x2
S 000379  M4x16 x2	T 269594  x4	U 013794  M4x22 x8	V 198478  L350 x2	W 098889  x8	X 000762  3.5x13 x28
Y 101608  7x50 x8	Z 230041  22x16 x4	AA 030579  x24			

5

B
000146 15x12

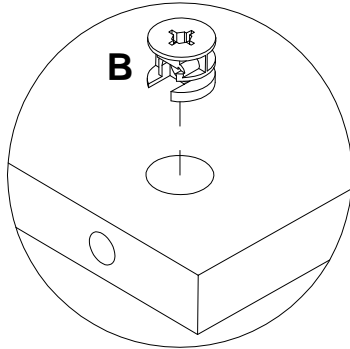
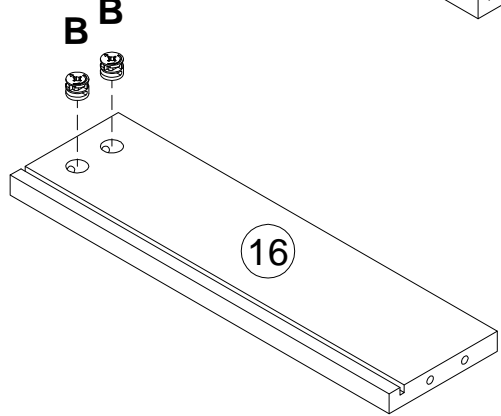
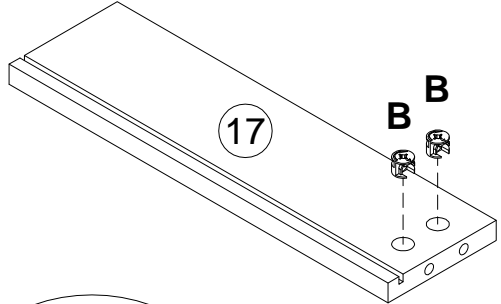
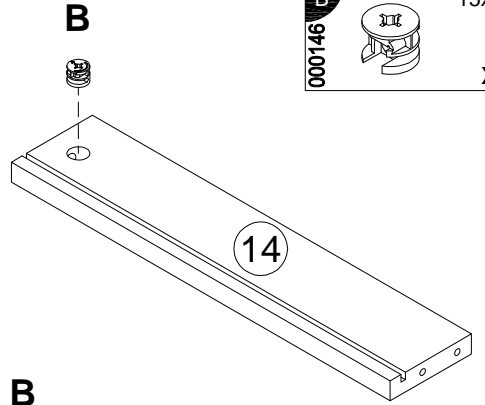
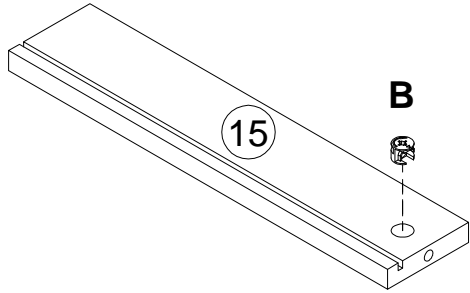
x6

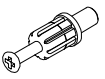

6

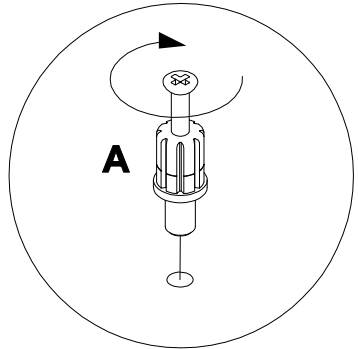
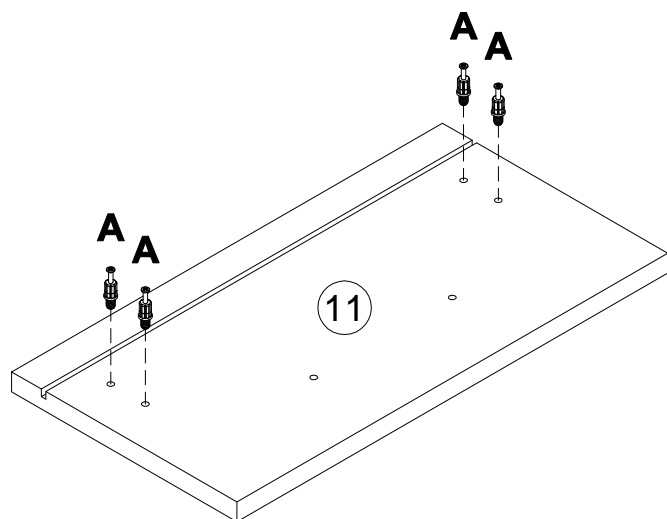
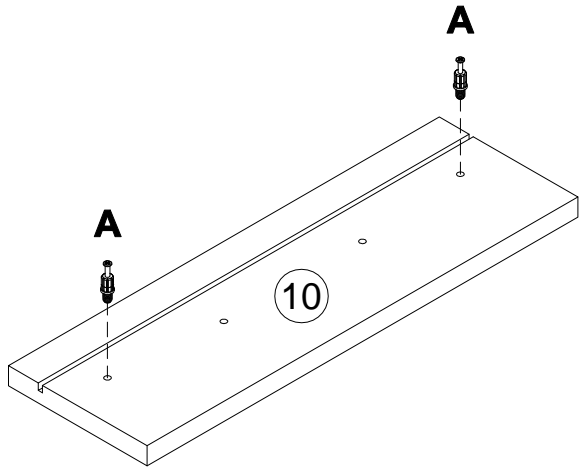
A
090913 7x32

x6

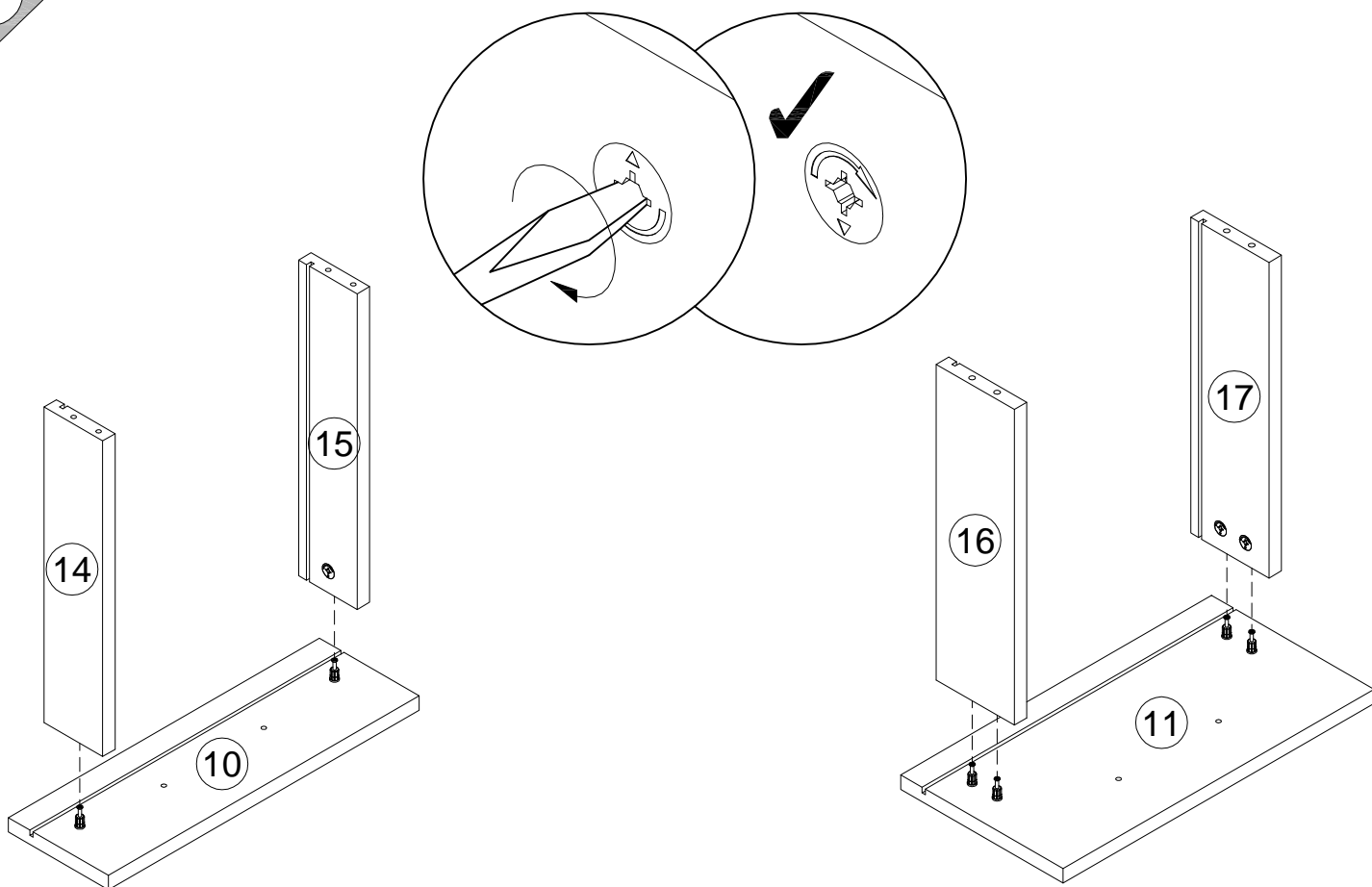

7

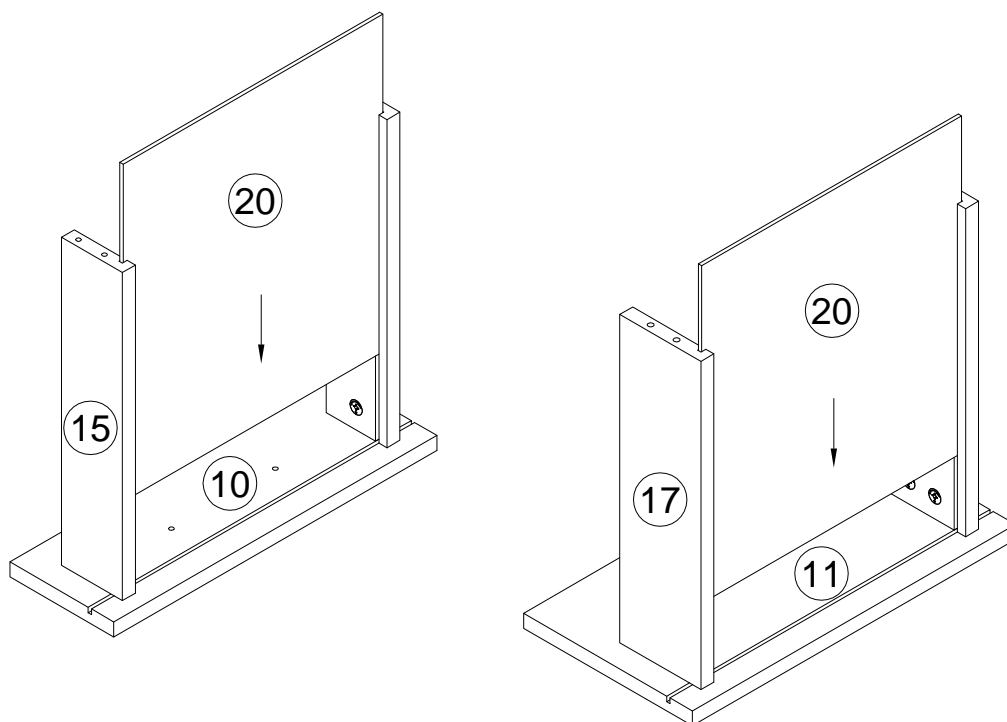

8



9

D	20x0.5	Y	7x50
	100640		x6

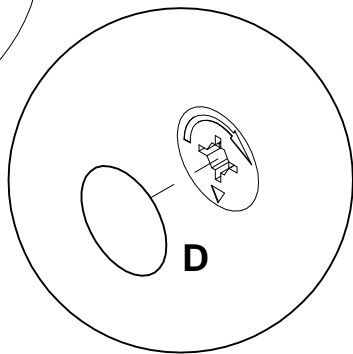
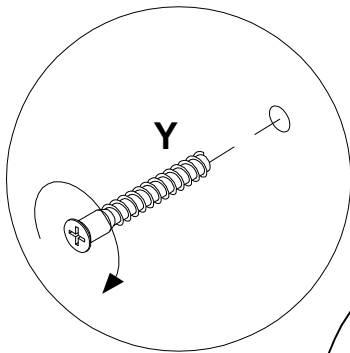
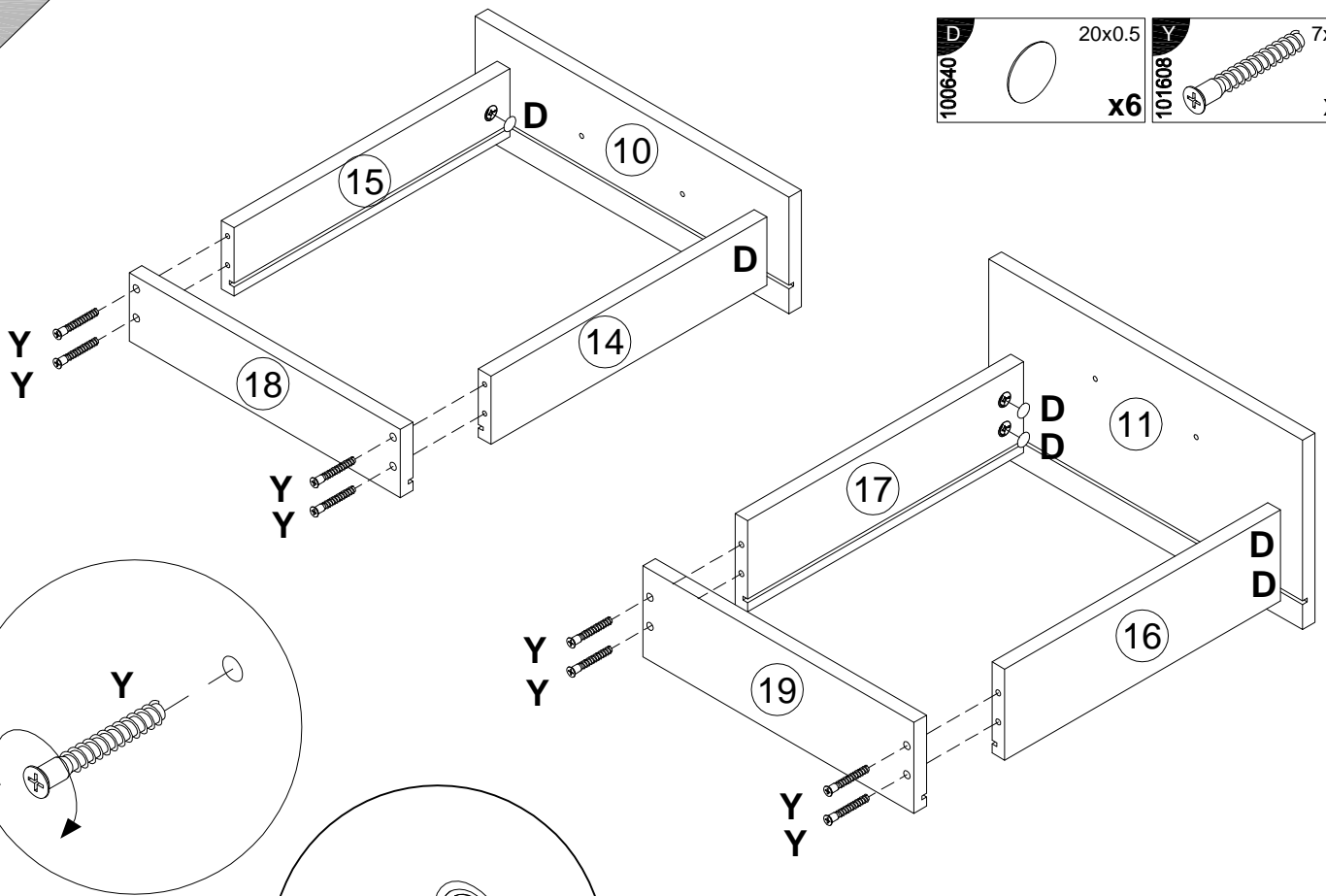

10

V	L350
	198478

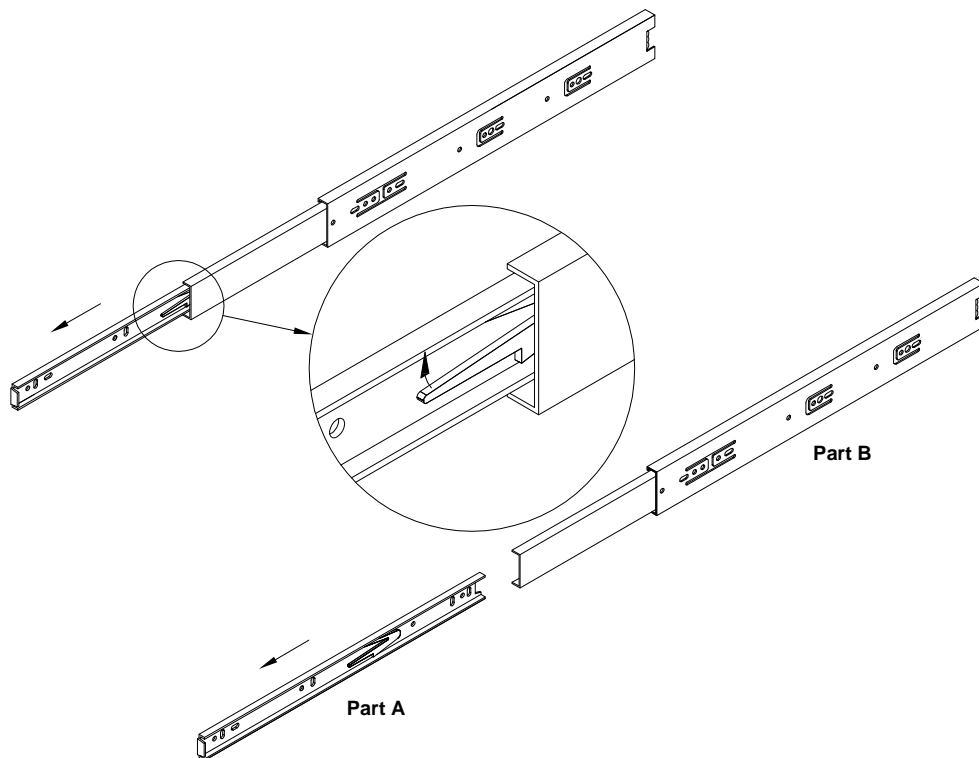

11

V	L350	X	3.5x13
198478		000762	
	x2		x12

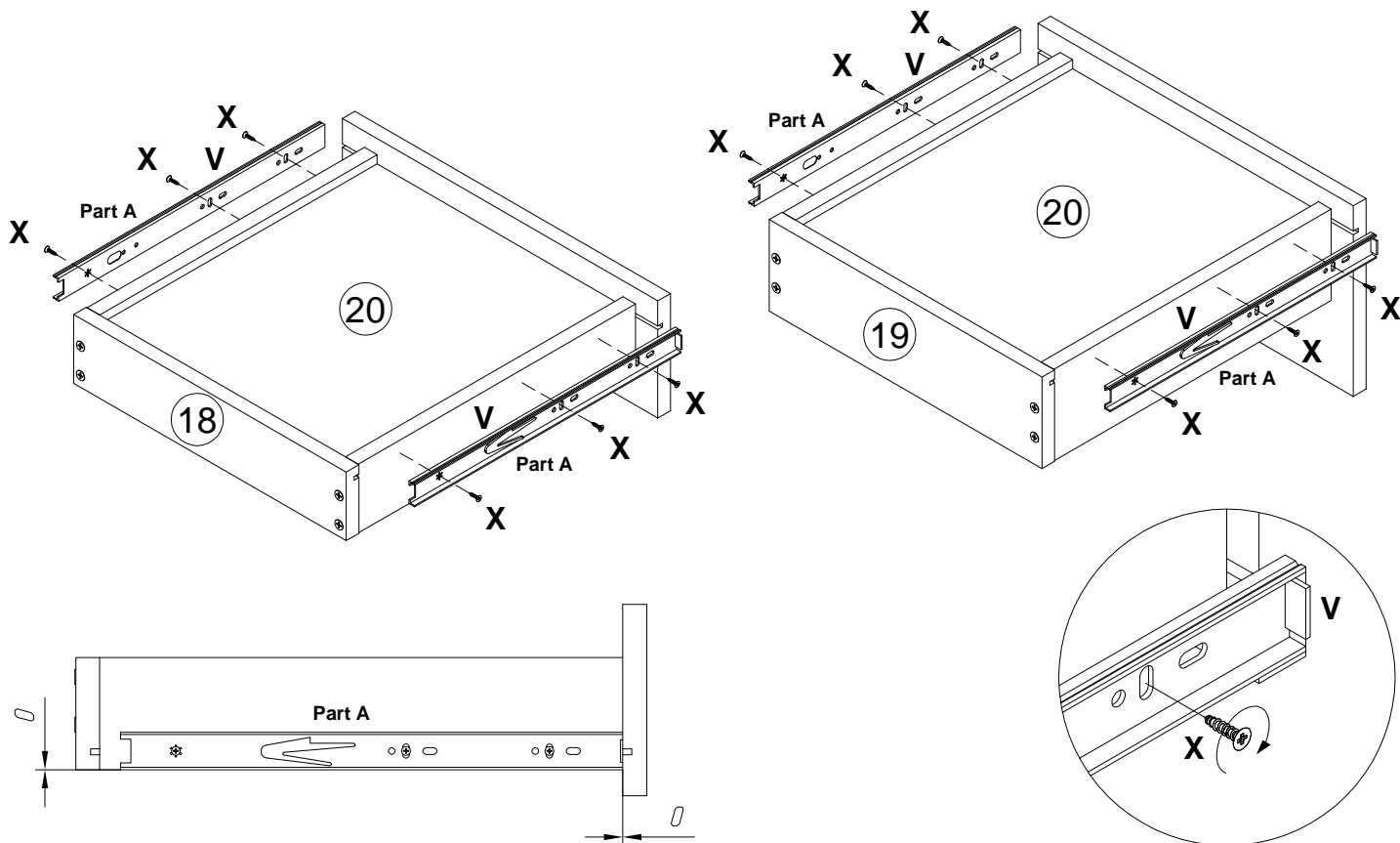

12

T		U	M4x22
269594		013794	
	x2		x4

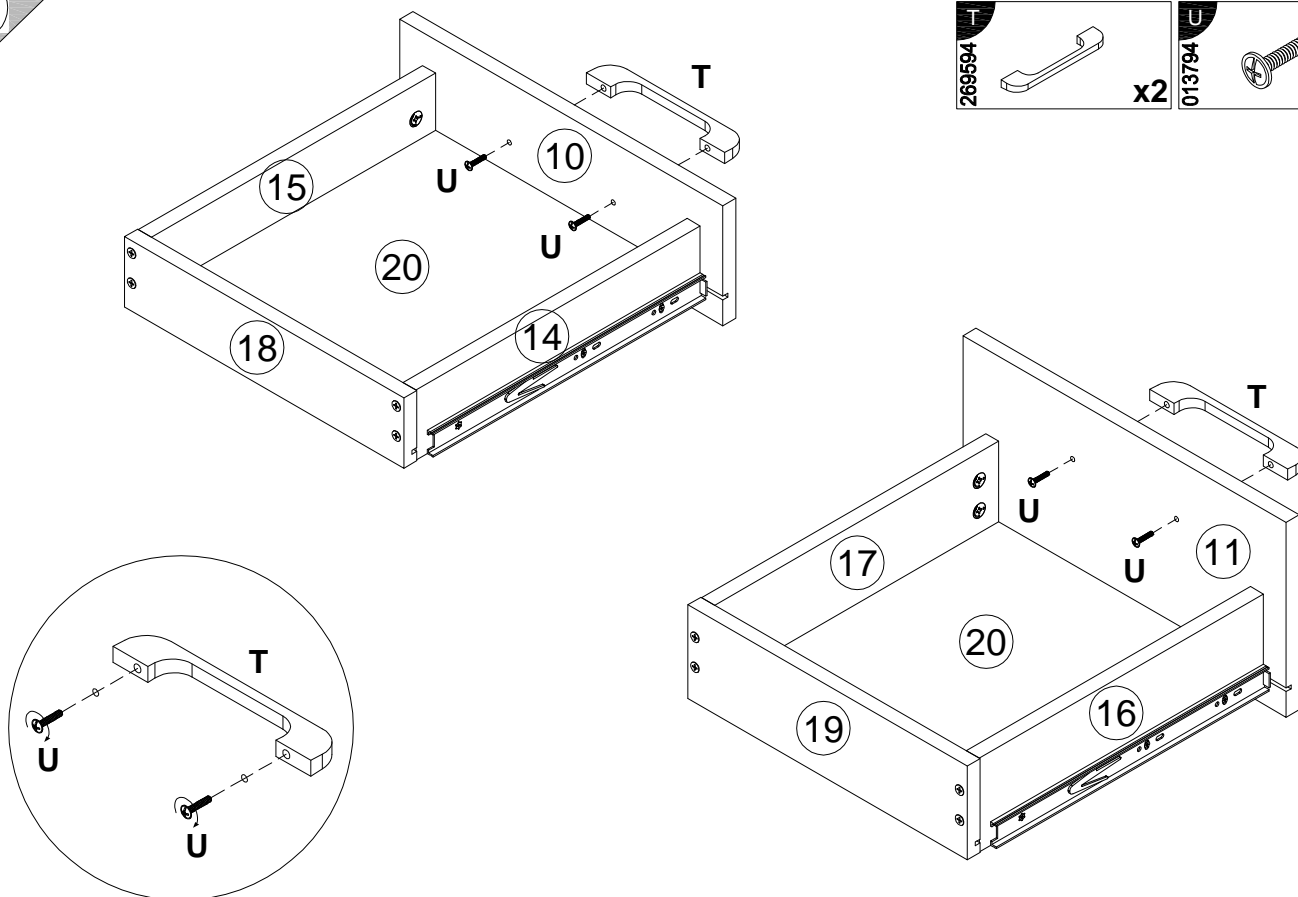



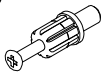

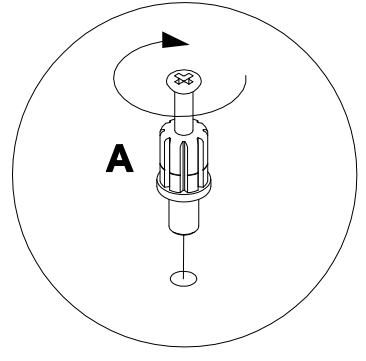
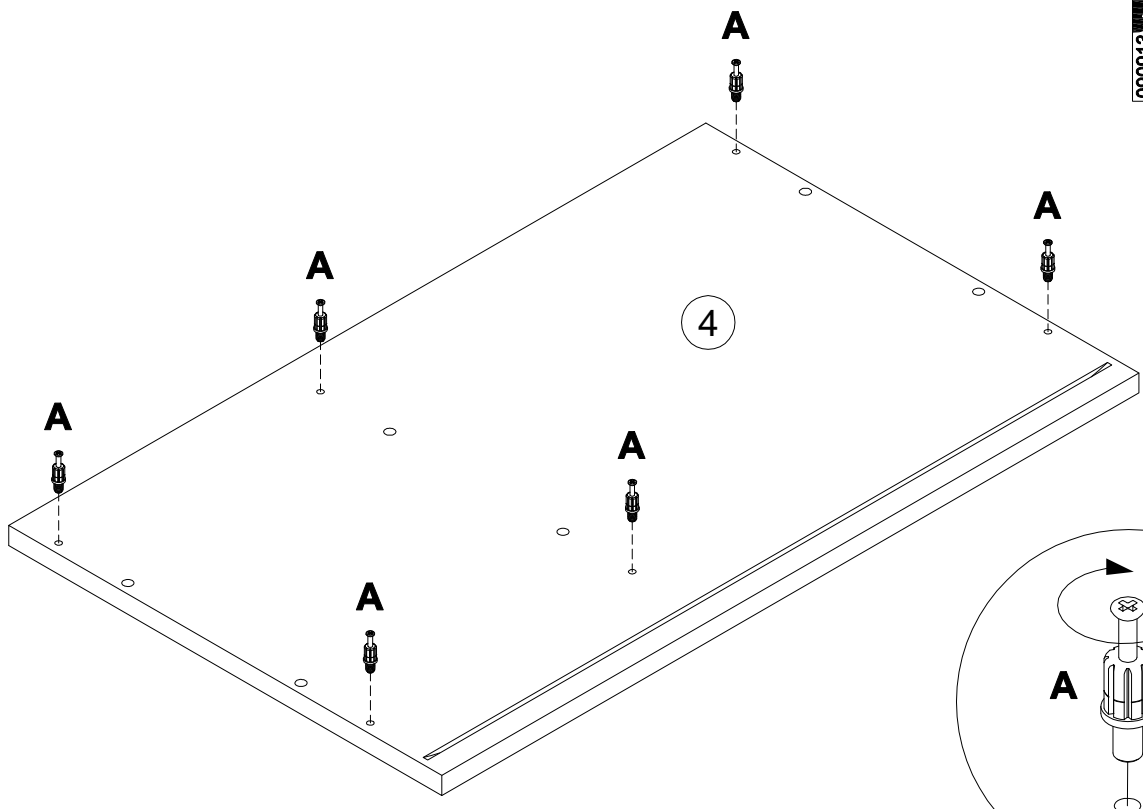
13

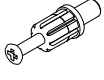

A		7x32
090913		x6



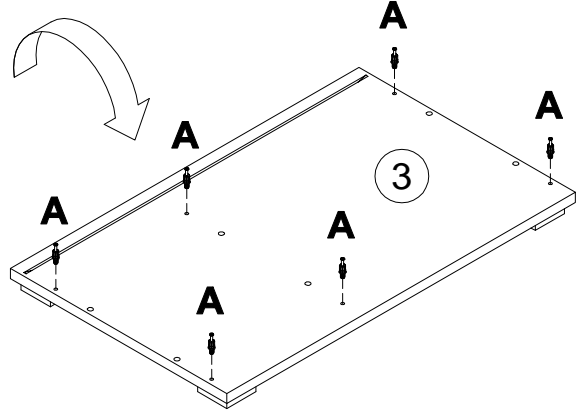
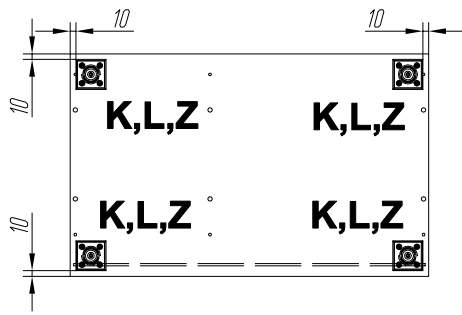
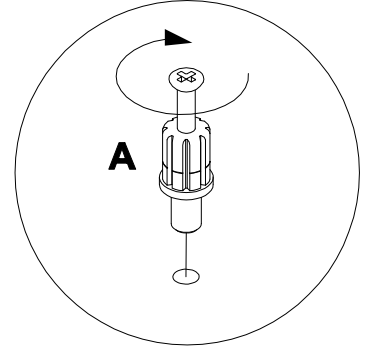
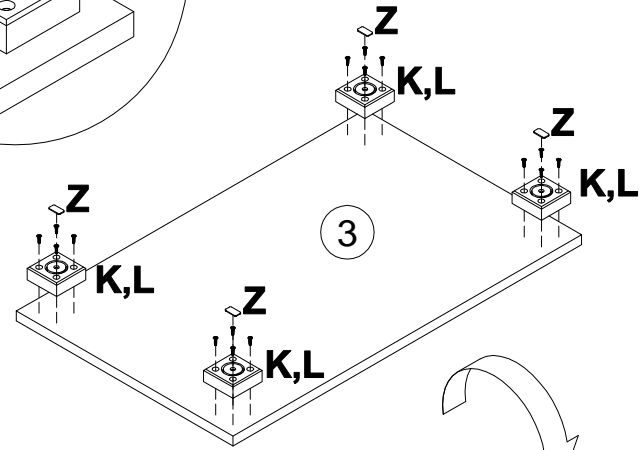
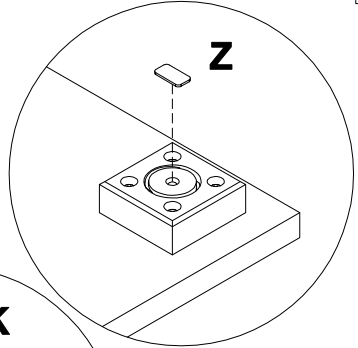
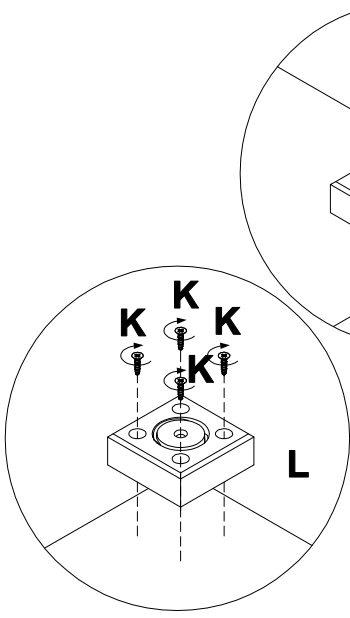

14

A		7x32	K		4x16	L		x4	Z		22x16
090913		x6	010942		x16	177473		x4	230041		x4



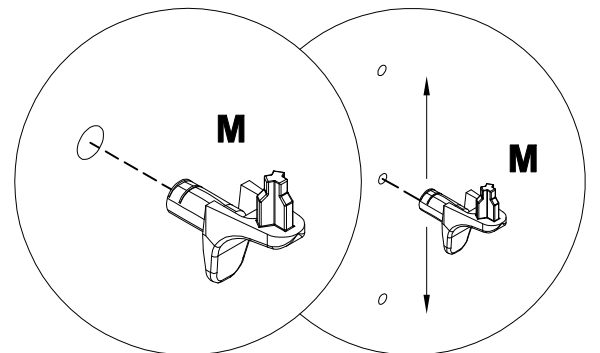
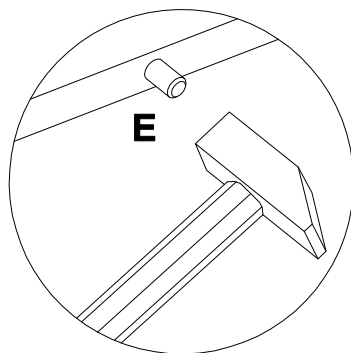
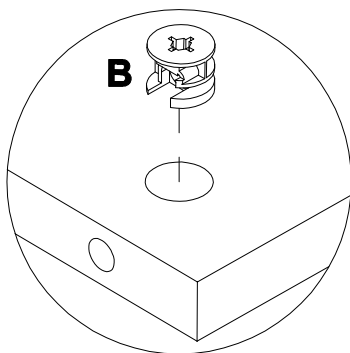
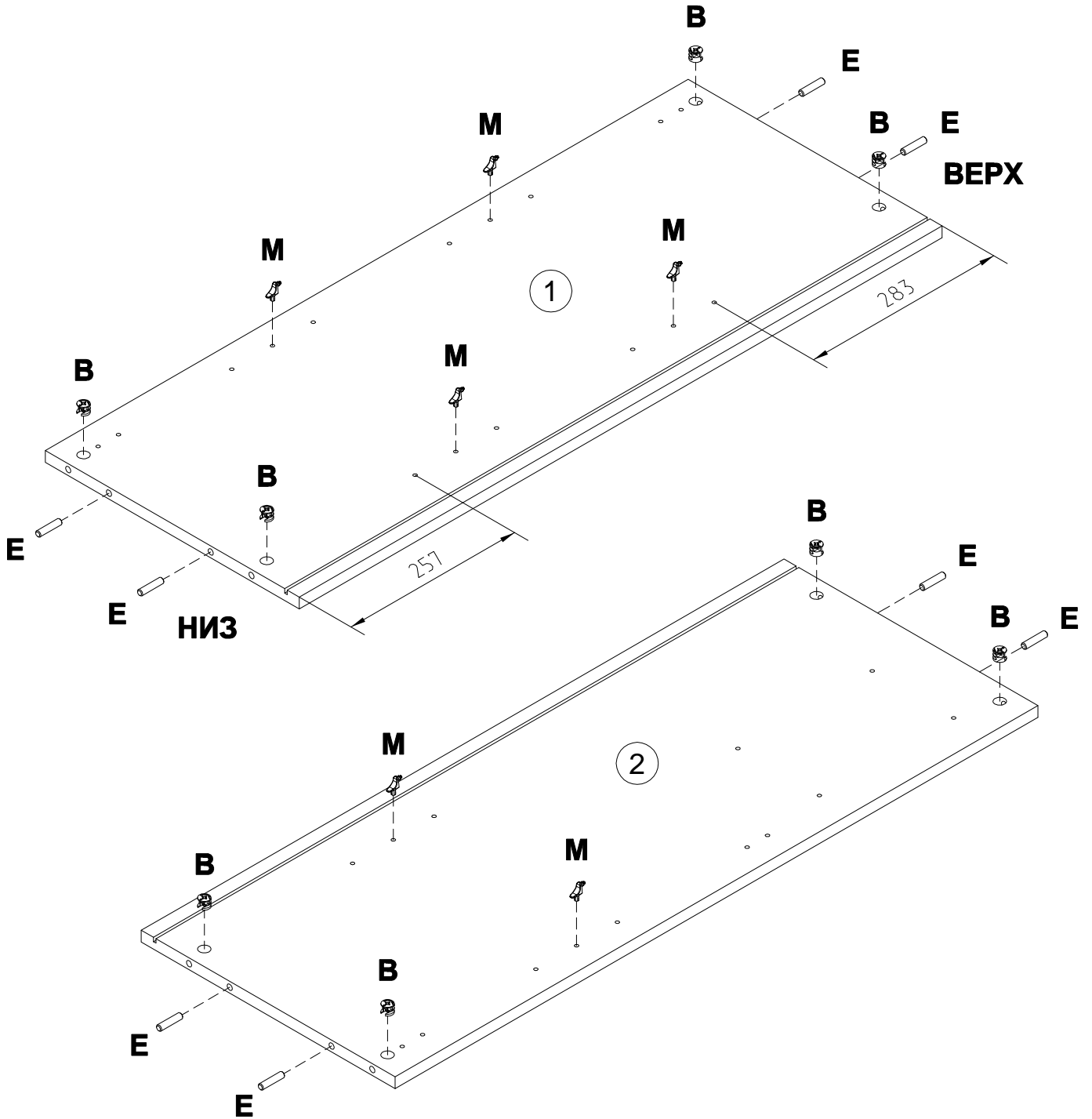

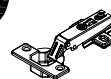
B 000146		15x12	E 000151		8x35	M 125913		x8	x8	x6
--------------------	--	-------	--------------------	--	------	--------------------	--	----	----	----

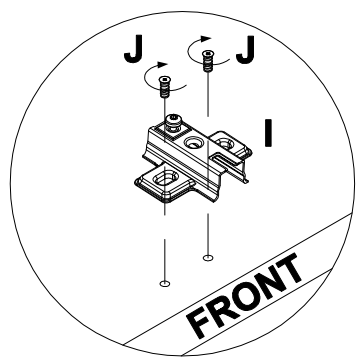
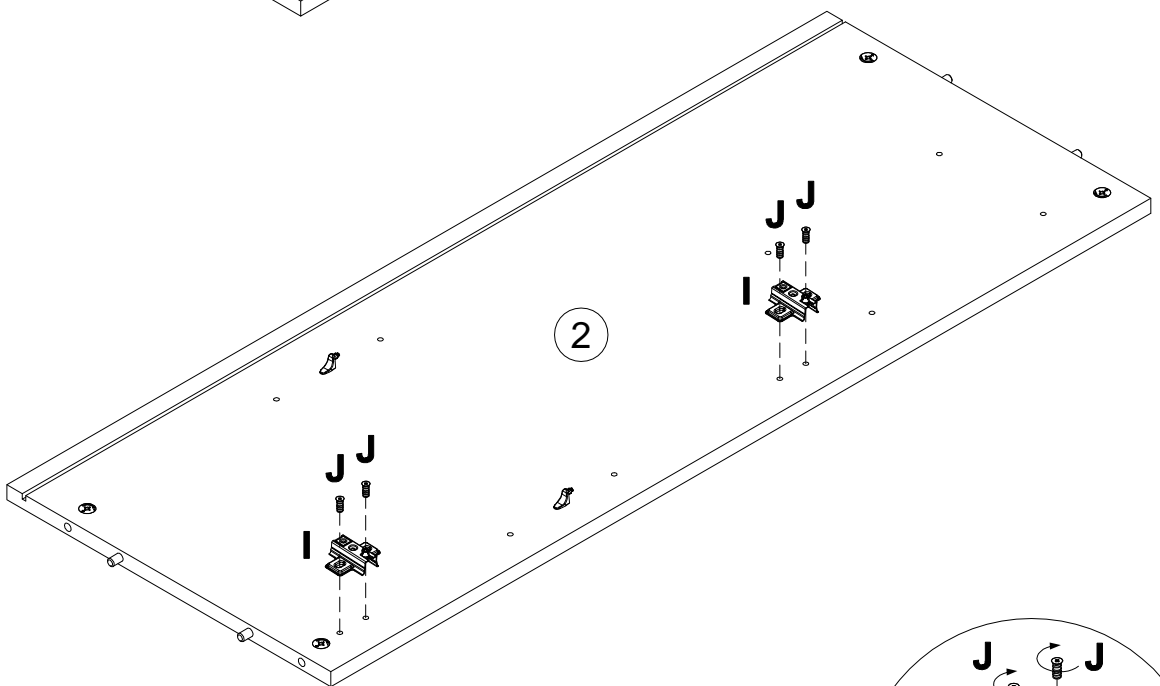
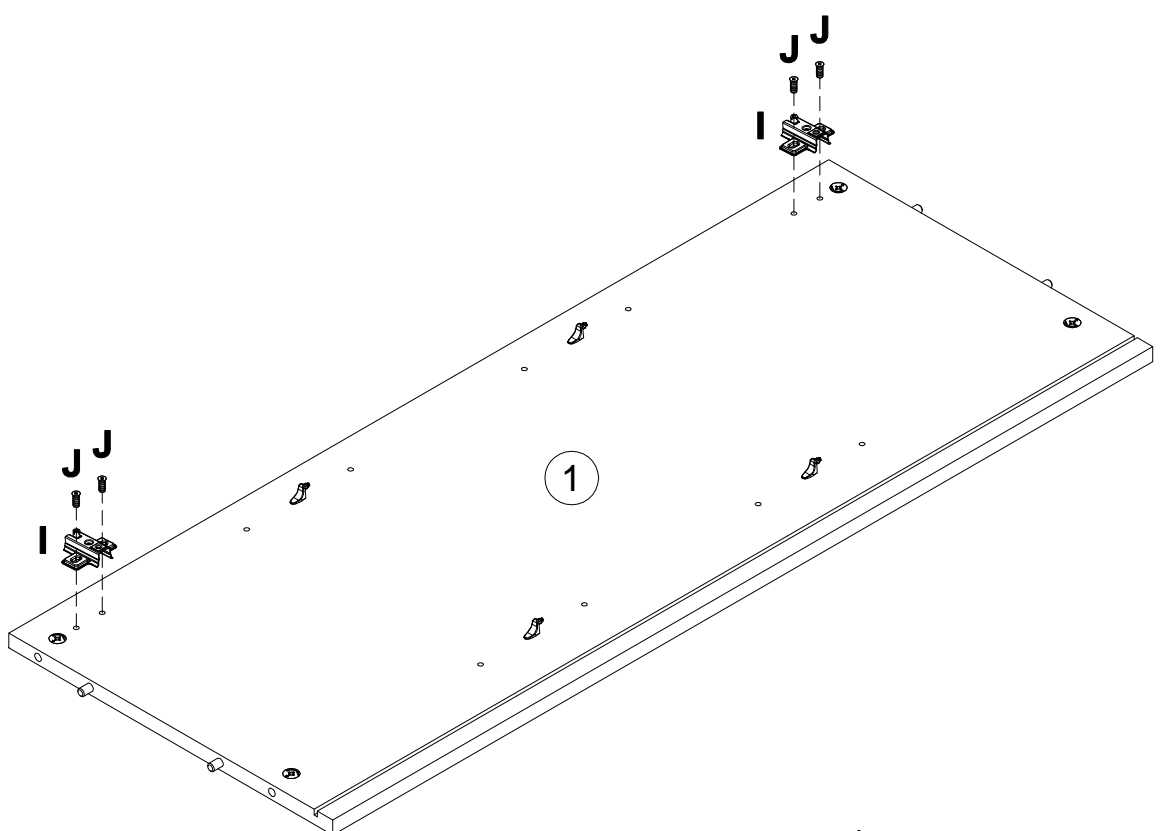

161423  x4	235594  6.3x16 x8
--	--

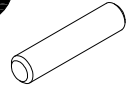

FRONT

B 000146	 15x12 x4	E 000151	 8x35 x4	M 125913	 x6
--------------------	--	--------------------	---	--------------------	---

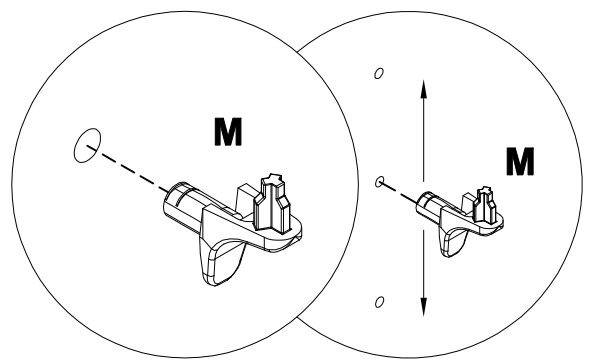
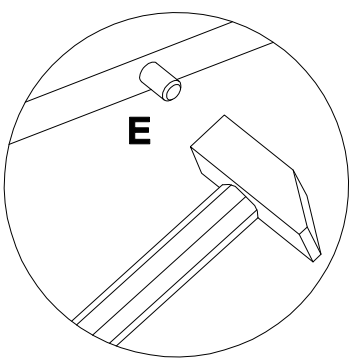
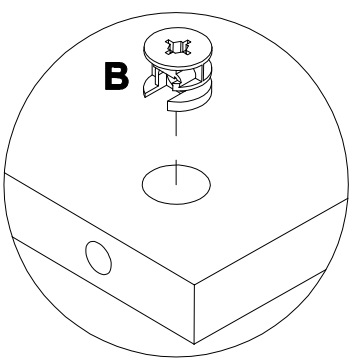
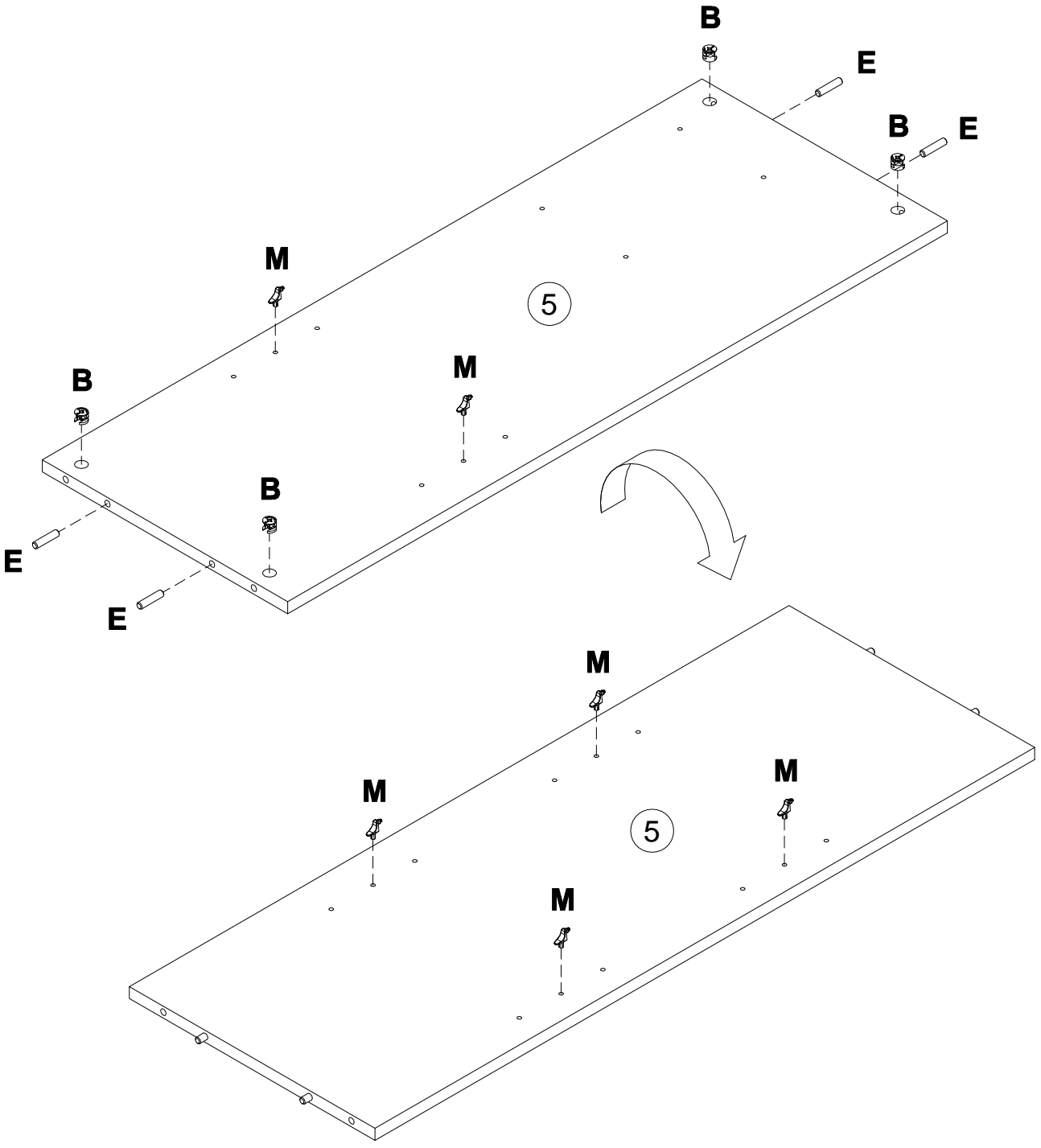

V 198478	L350 x2	W 098889	X 000762	3.5x13 x16
--------------------	-------------------	--------------------	--------------------	----------------------

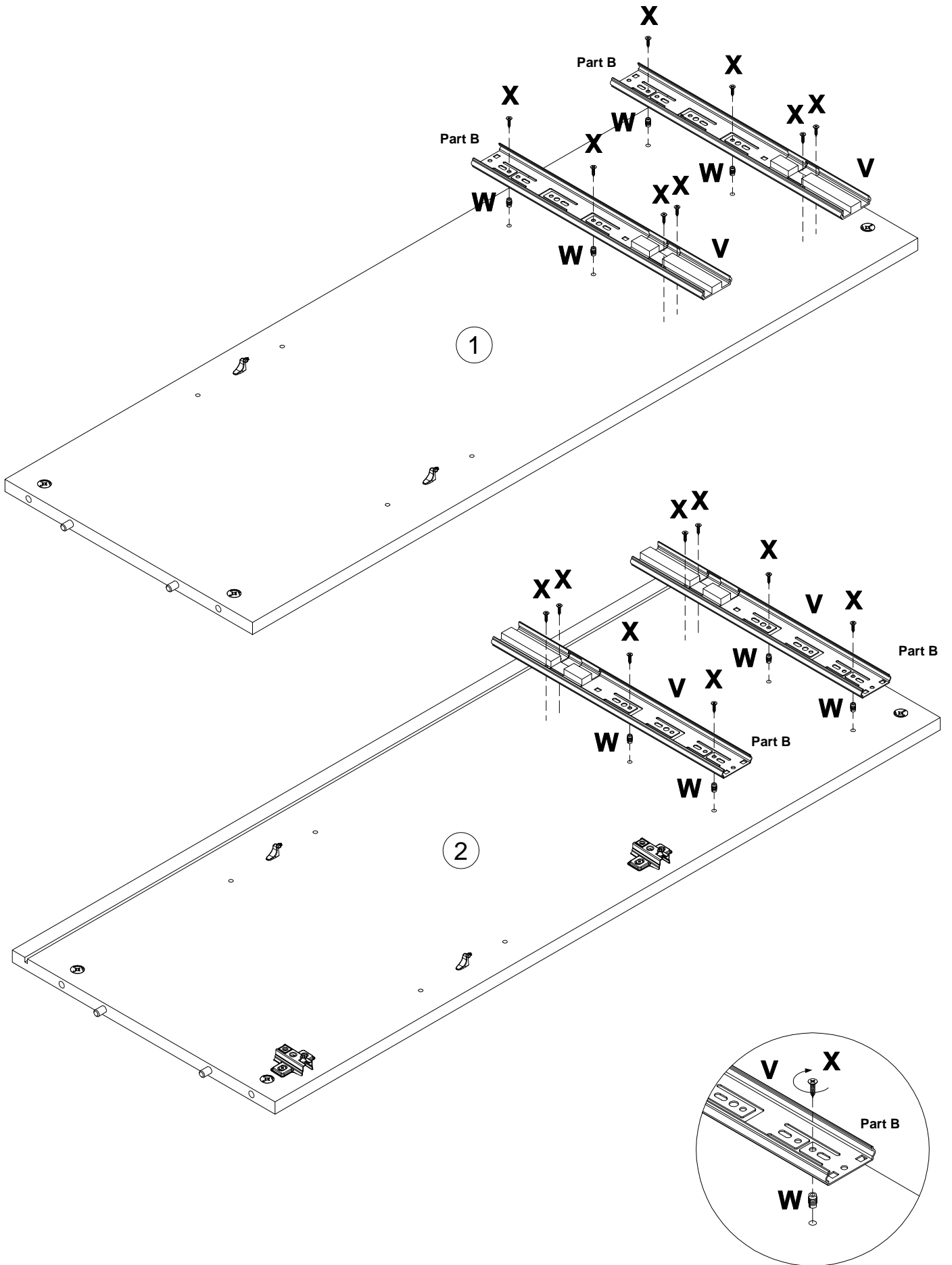

19

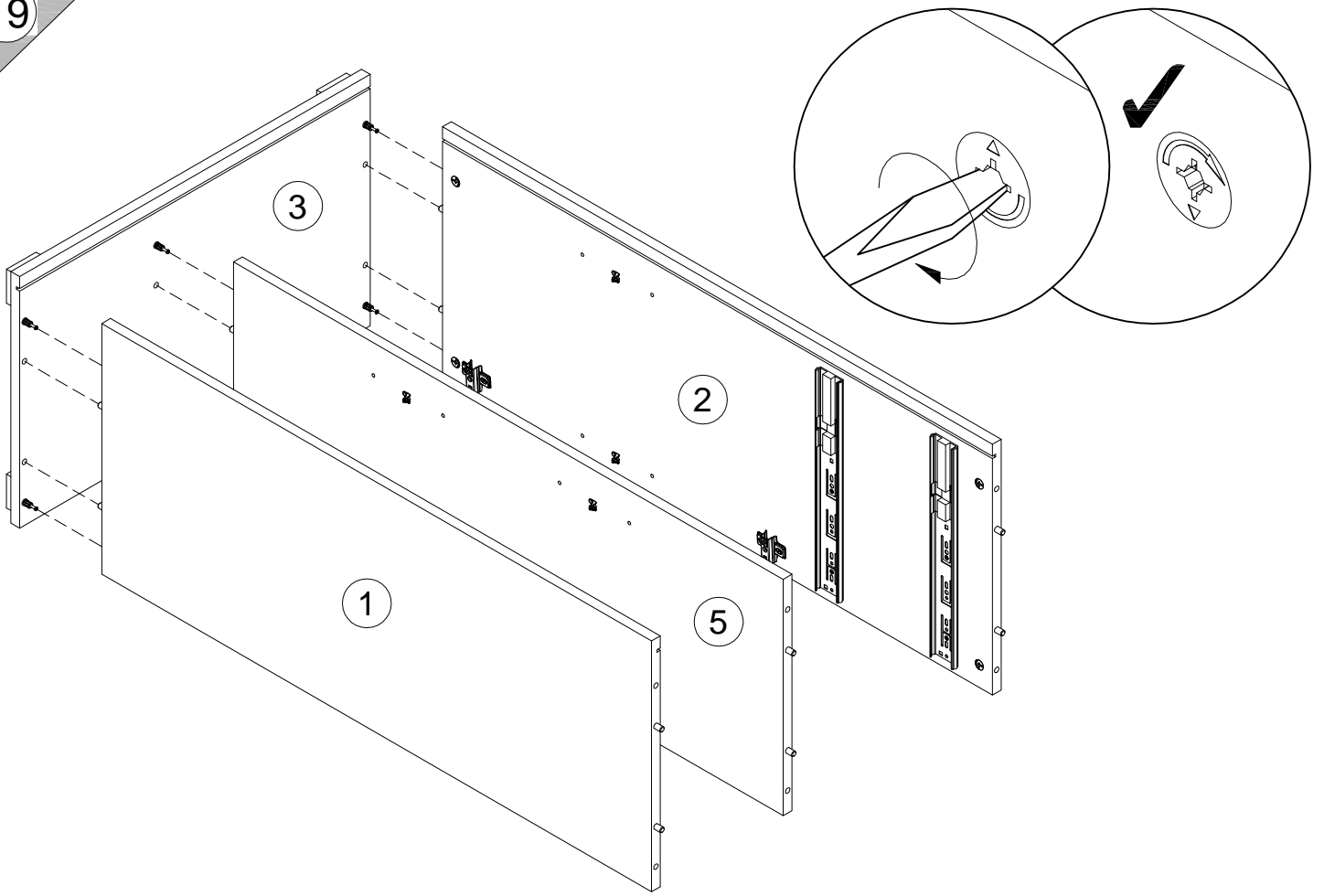

20

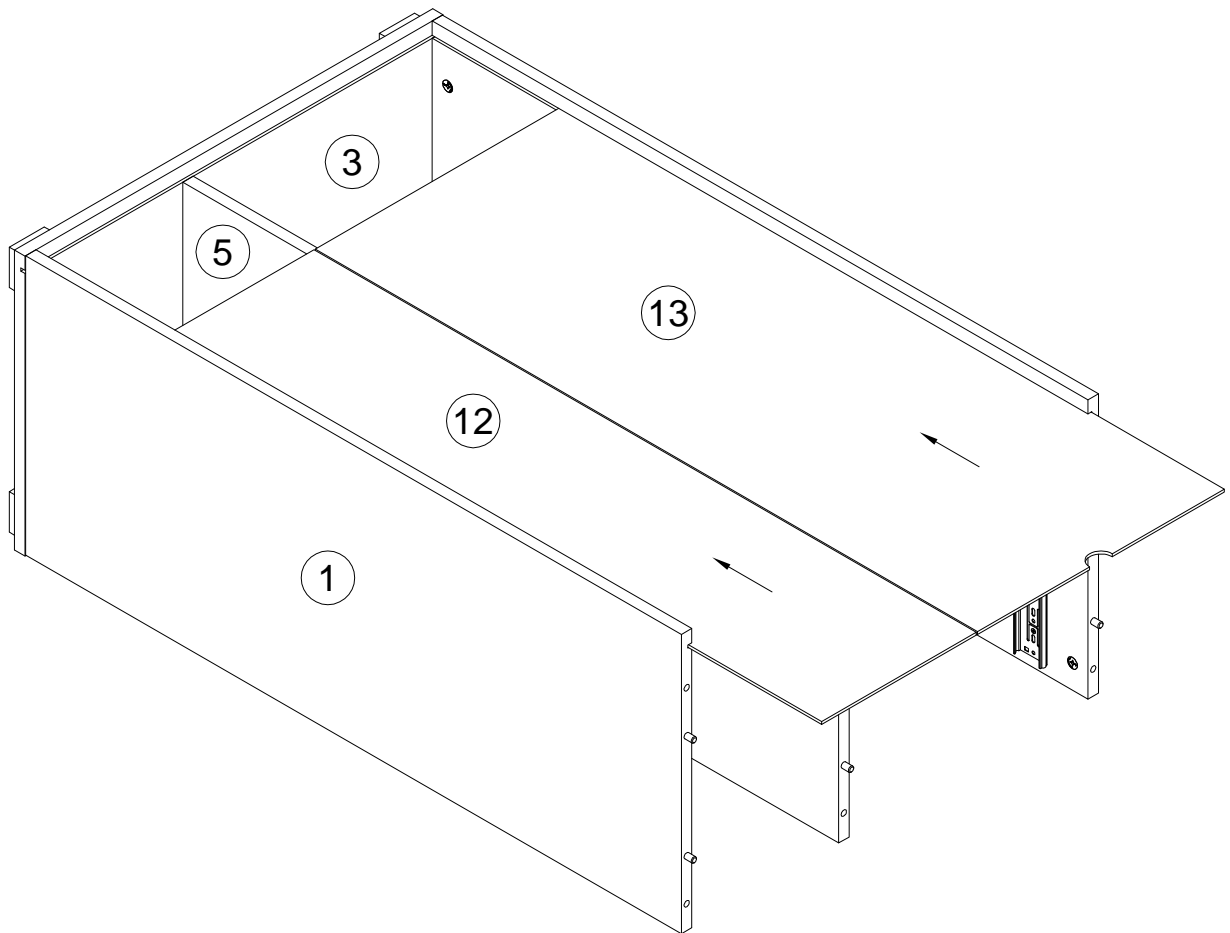

21

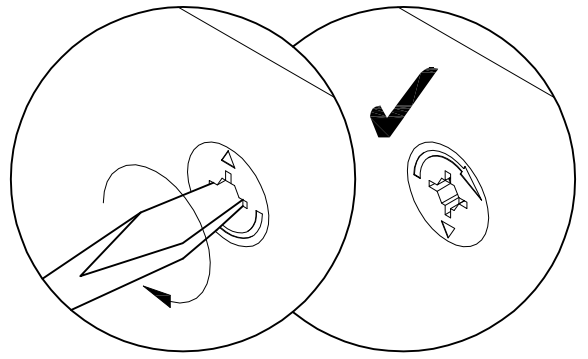
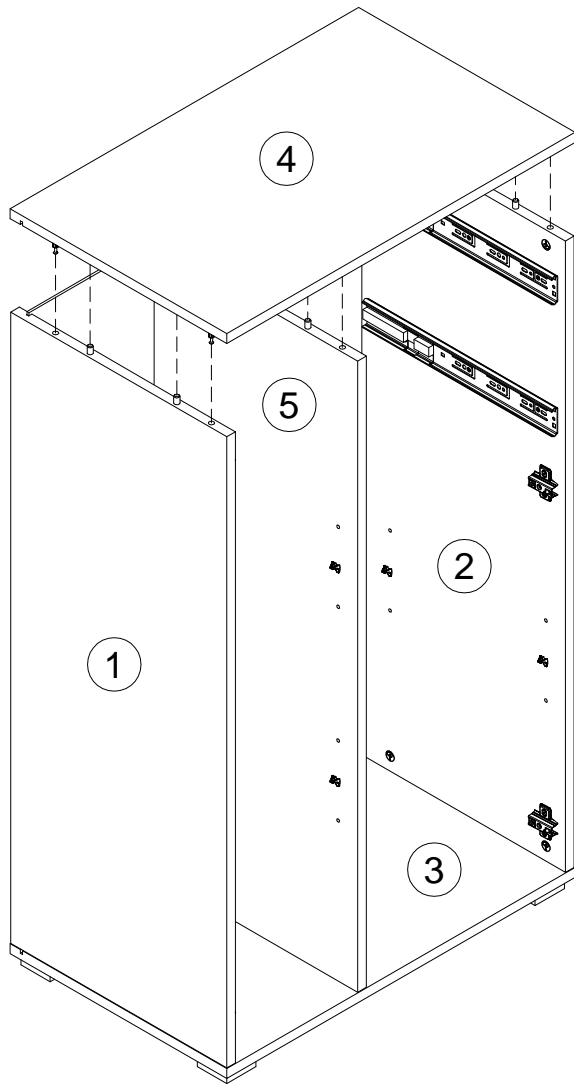



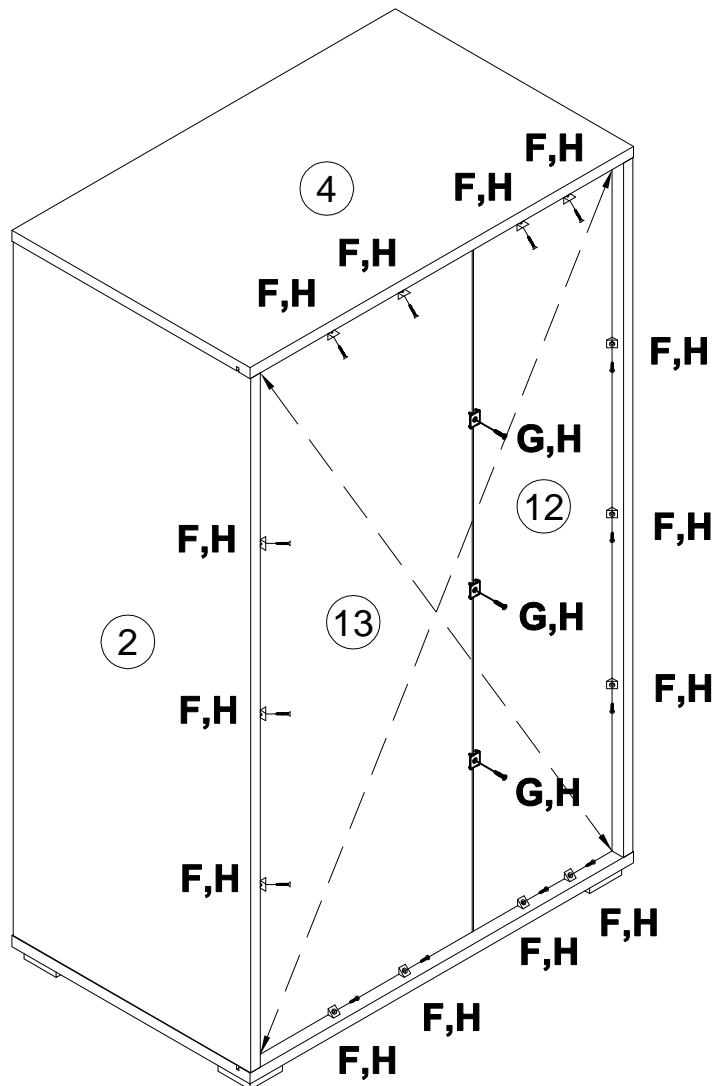
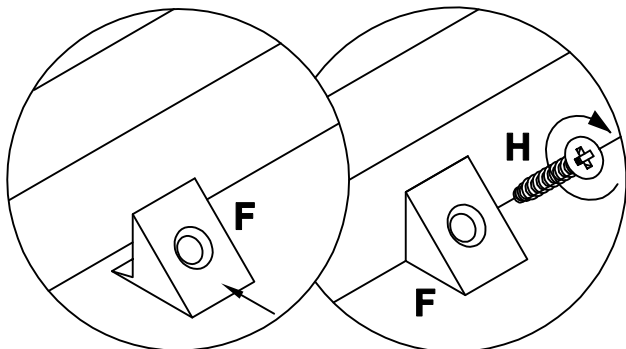
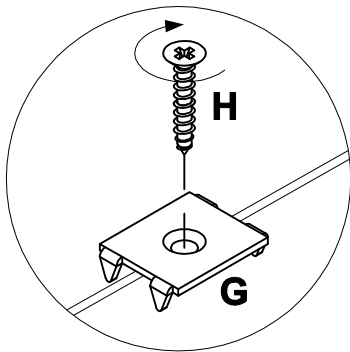
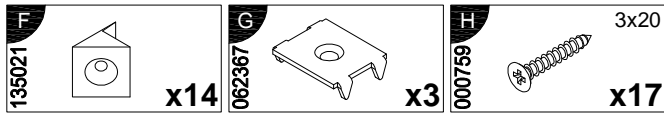

22

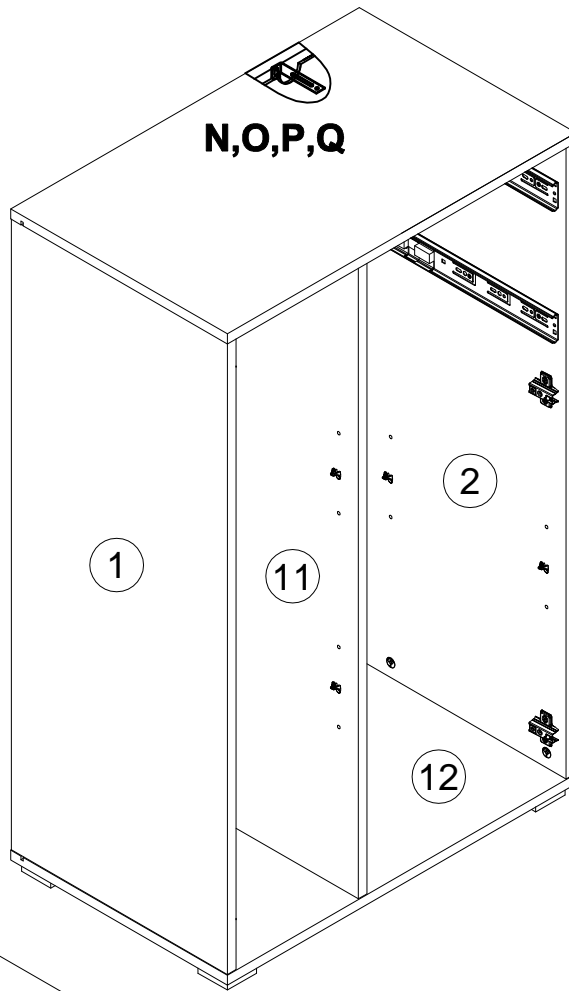
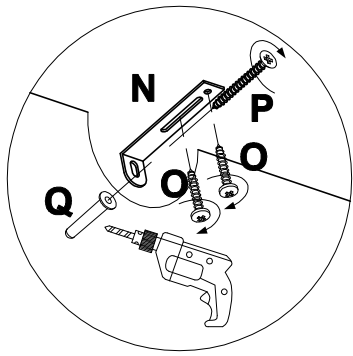

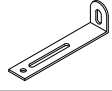
23



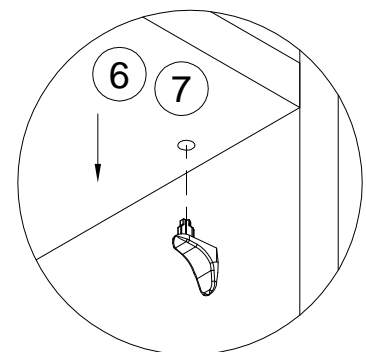
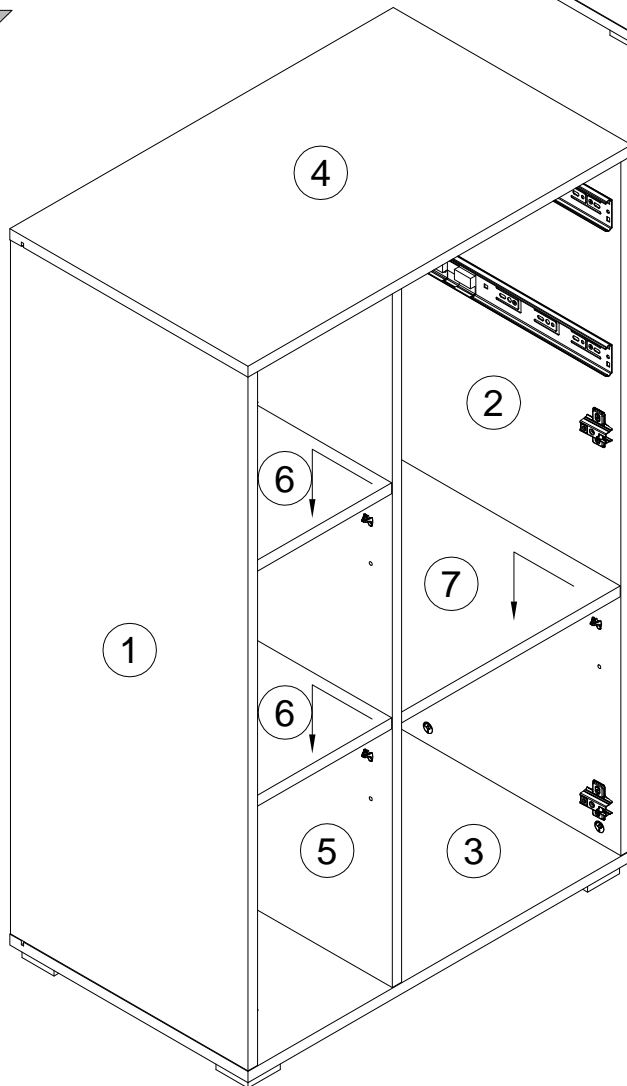

- N** 155999  **x1**
- O** 000754  3.5x16 **x2**
- P** 090185  4.5x45 **x1**
- Q** 013859  8x40 **x1**

24

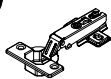

25

I		K		4x16
161423	x4	010942	x8	

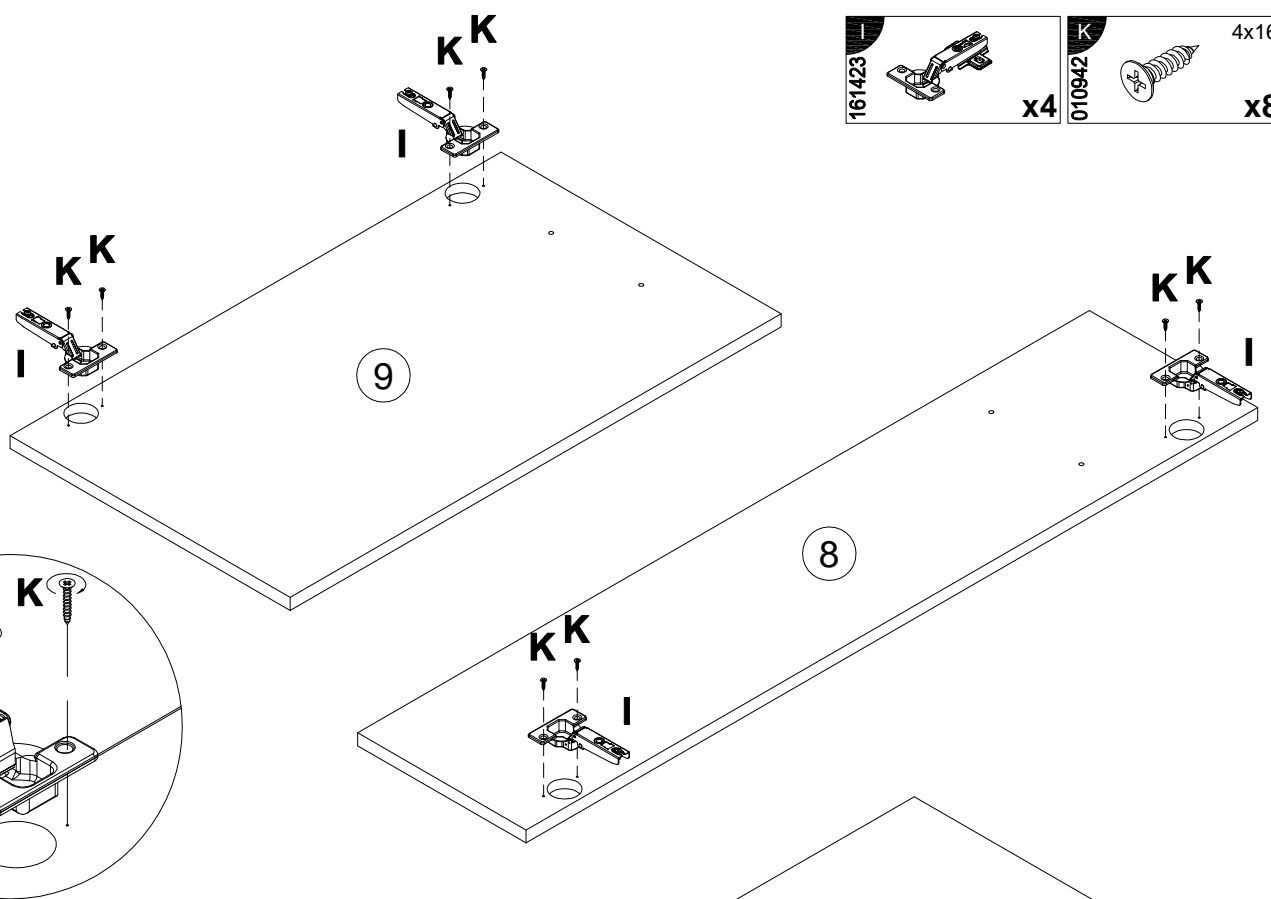

26

C		20x0.5	AA	
100640	x8		030579	x24

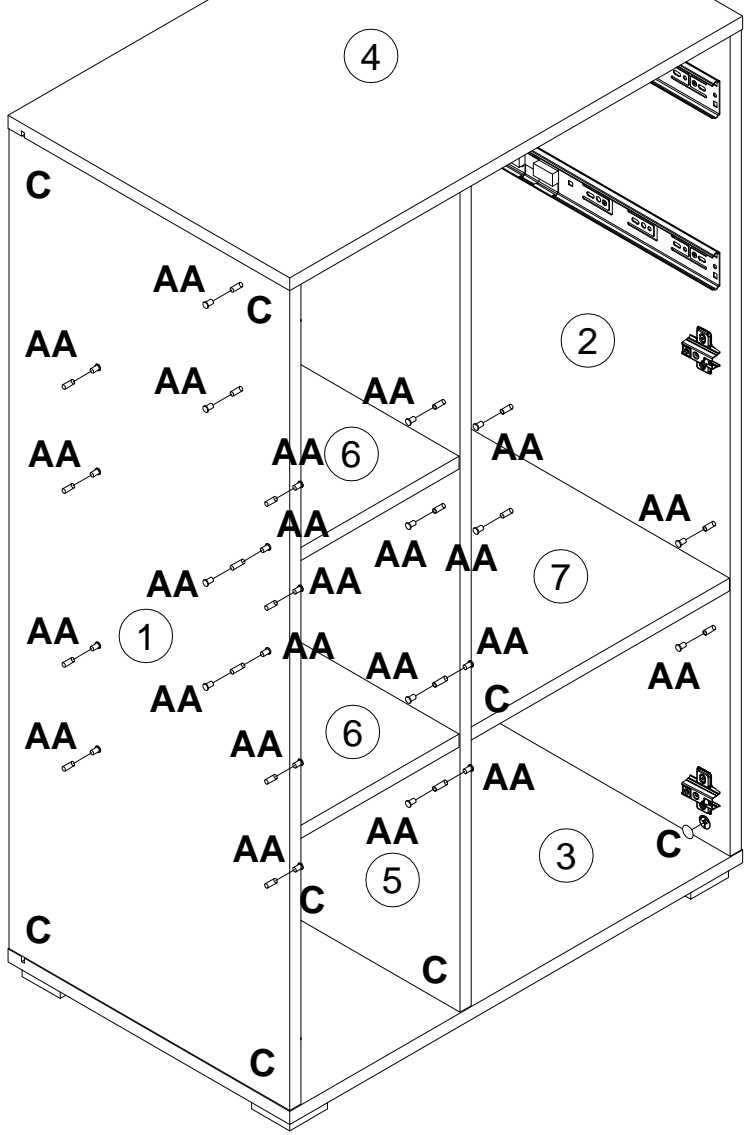
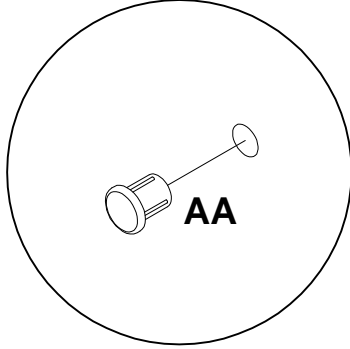
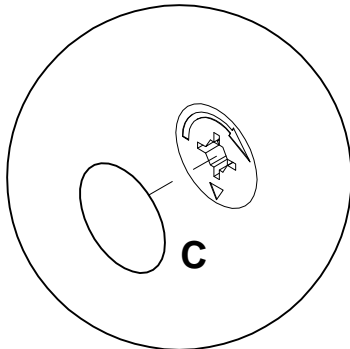

27

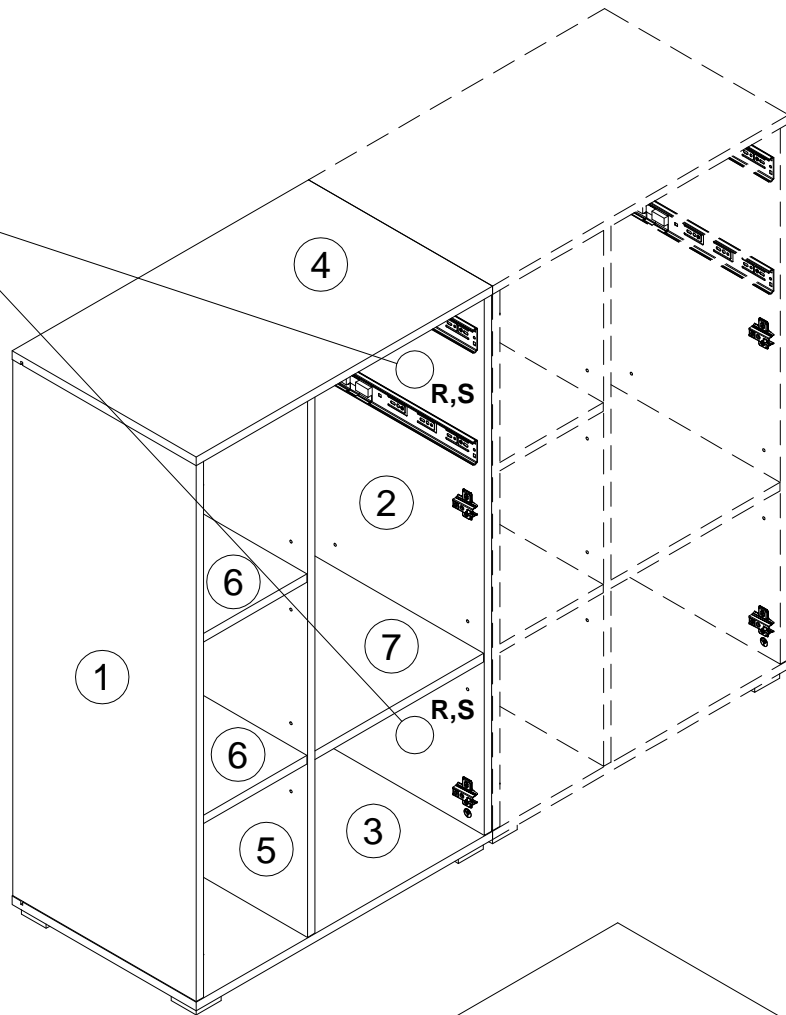
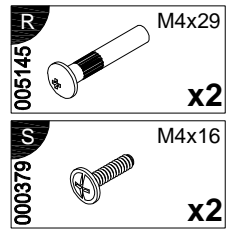
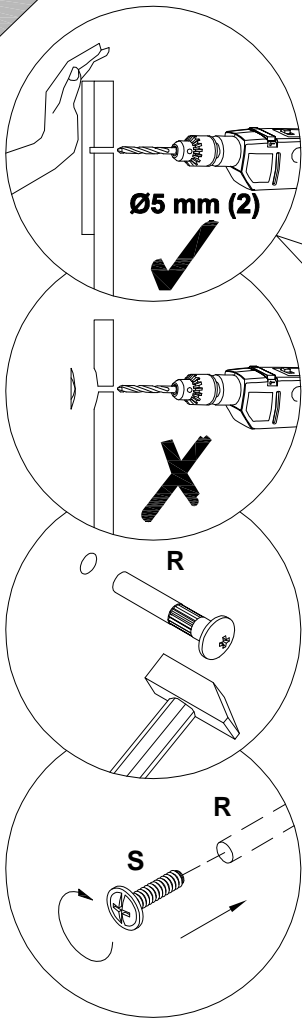

28

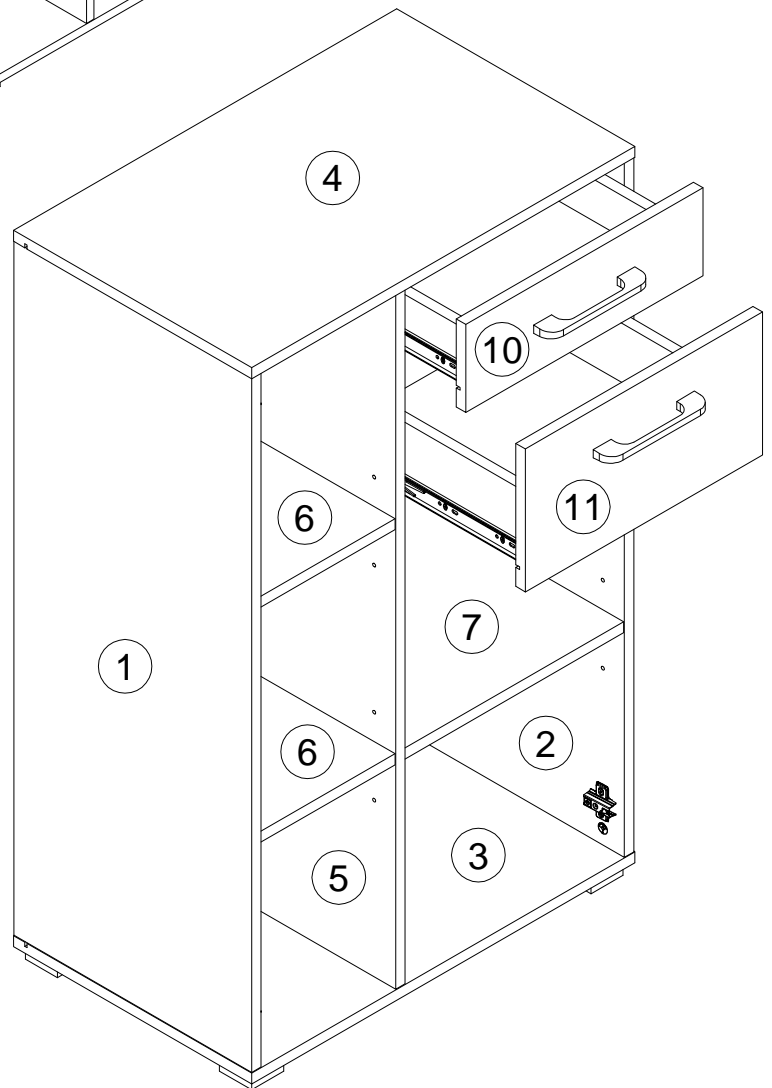
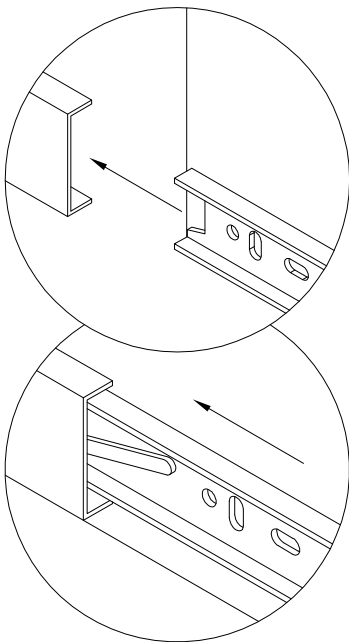

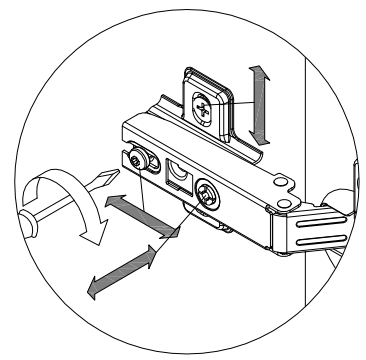
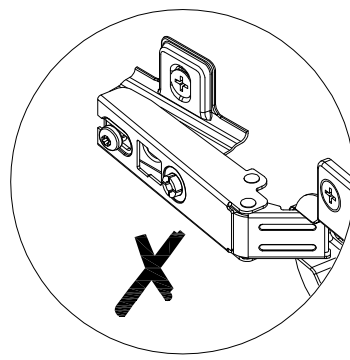
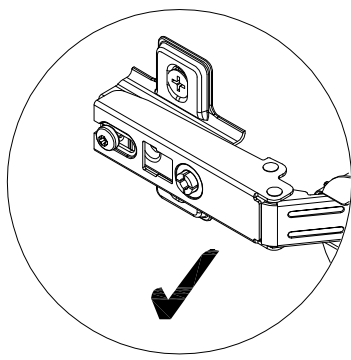
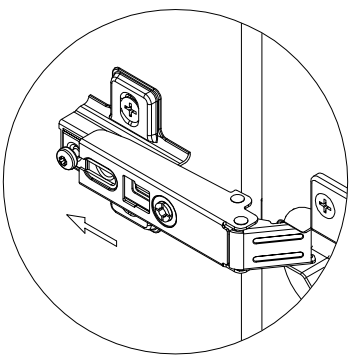
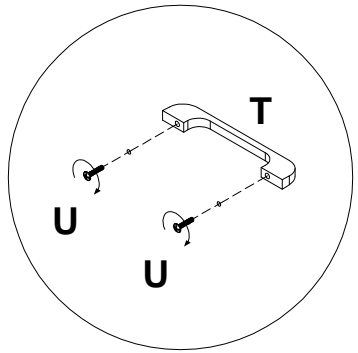
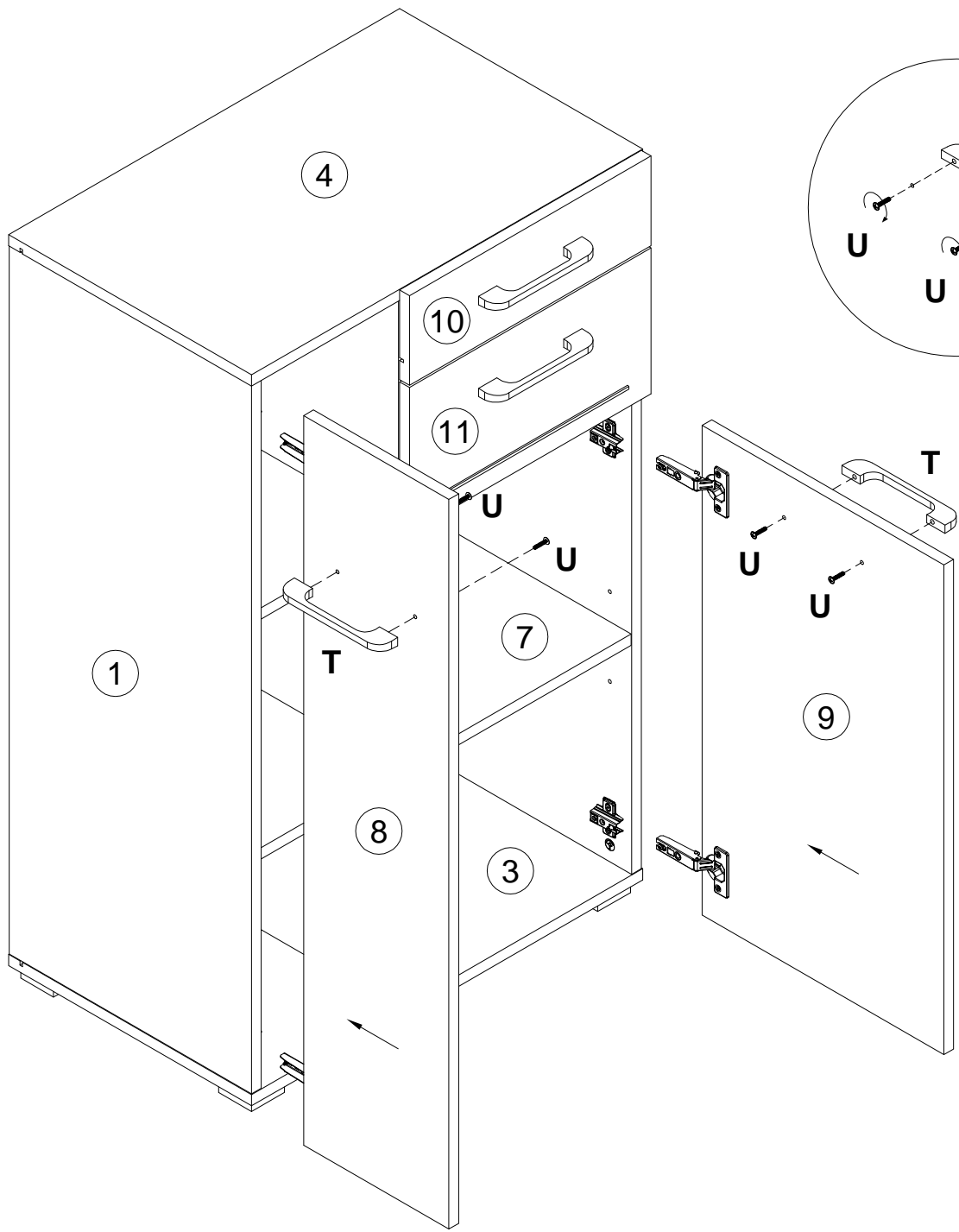
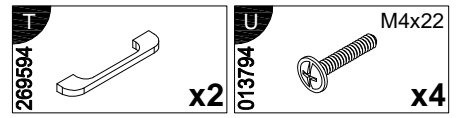

Инструкция по уходу за мебелью и правила эксплуатации

1. Мебель рекомендуется эксплуатировать в бытовых помещениях с температурой воздуха не ниже +2°С и относительной влажностью 45-70%.
2. Мебель должна быть защищена от воздействия прямых солнечных лучей, так как это вредит внешнему виду изделий и может изменить цвет поверхности.
3. Не следует ставить на поверхность мебели горячие предметы.
4. Случайно попавшую на поверхность изделия влагу, жидкость следует снять сухой тканью.
5. Удаление пыли с полированной или лакированной поверхности следует производить сухой тканью (фланель, миткаль).
6. Полированные и лакированные поверхности мебели рекомендуется освежать специально предназначенными для этого средствами.
7. Очищать стекла рекомендуется специальными составами, нанесенными на мягкую ткань.
8. Не допускается применение соды, стиральных порошков, абразивных паст, порошков и прочих, не предназначенных для ухода за изделиями мебели препаратов.

В связи с постоянной работой, направленной на улучшение потребительских свойств мебели, предприятие-изготовитель оставляет за собой право на изменения конструкции, не влияющие на качество и внешний вид изделия.